

- 1 A bullet of mass 2.0 g is fired horizontally into a block of wood of mass 600 g. The block is suspended from strings so that it is free to move in a vertical plane. The bullet buries itself in the block. The block and bullet rise together through a vertical distance of 8.6 cm, as shown in Fig. 3.1.

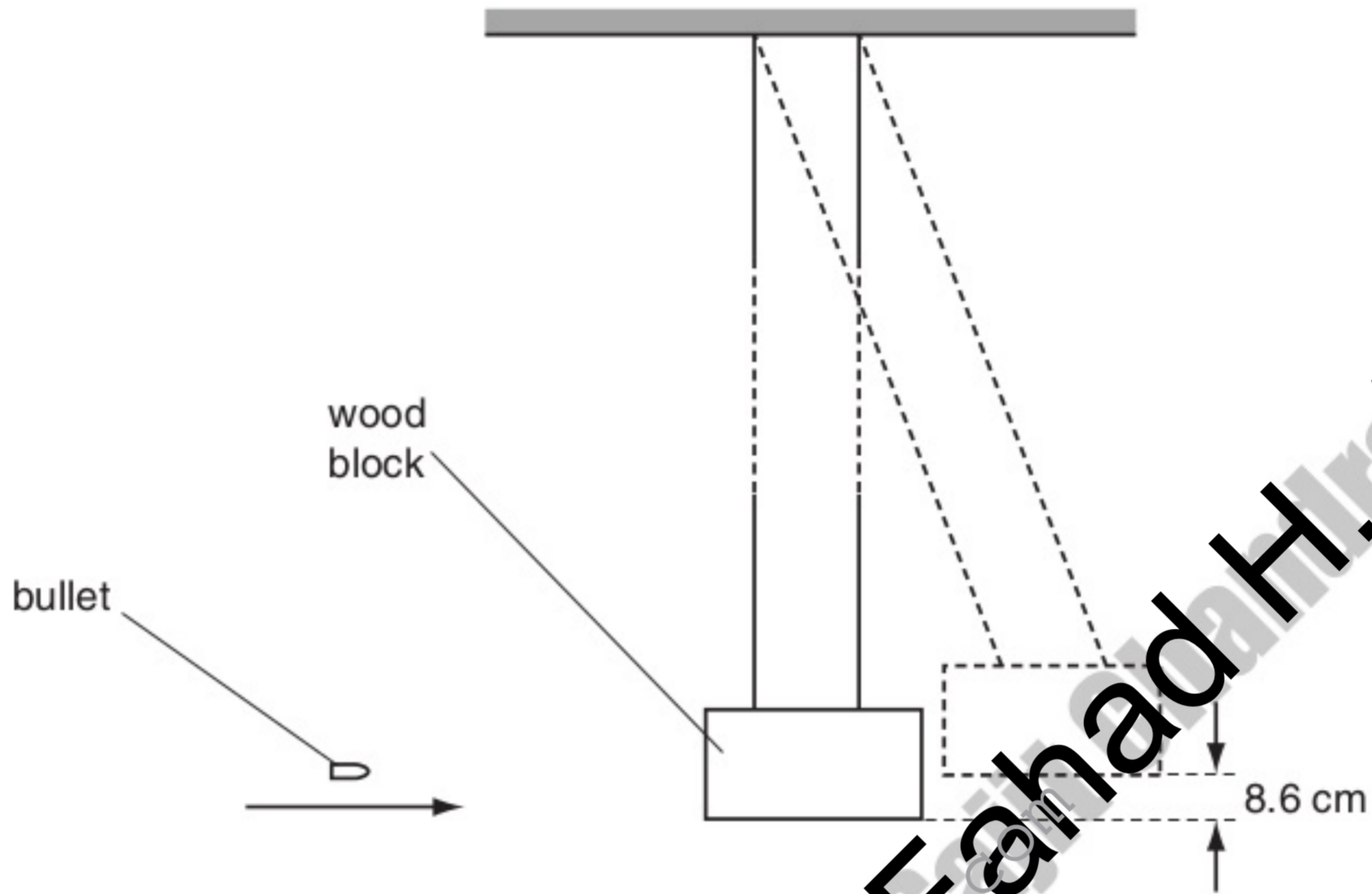

Fig. 3.1

- (a) (i) Calculate the change in gravitational potential energy of the block and bullet.

change = J [2]

- (ii) Show that the initial speed of the block and the bullet, after they began to move off together, was 1.3 m s^{-1} .

[1]

- (b) Using the information in (a)(ii) and the principle of conservation of momentum, determine the speed of the bullet before the impact with the block.

For Examiner's Use

speed = m s⁻¹ [2]

- (c) (i) Calculate the kinetic energy of the bullet just before impact.

kinetic energy = J [2]

- (ii) State and explain what can be deduced from your answers to (c)(i) and (a)(i) about the type of collision between the bullet and the block.

.....

.....

..... [2]

Compiled and rearranged by Fahad H. Ahmad

- 2 An experiment is conducted on the surface of the planet Mars.
A sphere of mass 0.78 kg is projected almost vertically upwards from the surface of the planet. The variation with time t of the vertical velocity v in the upward direction is shown in Fig. 2.1.

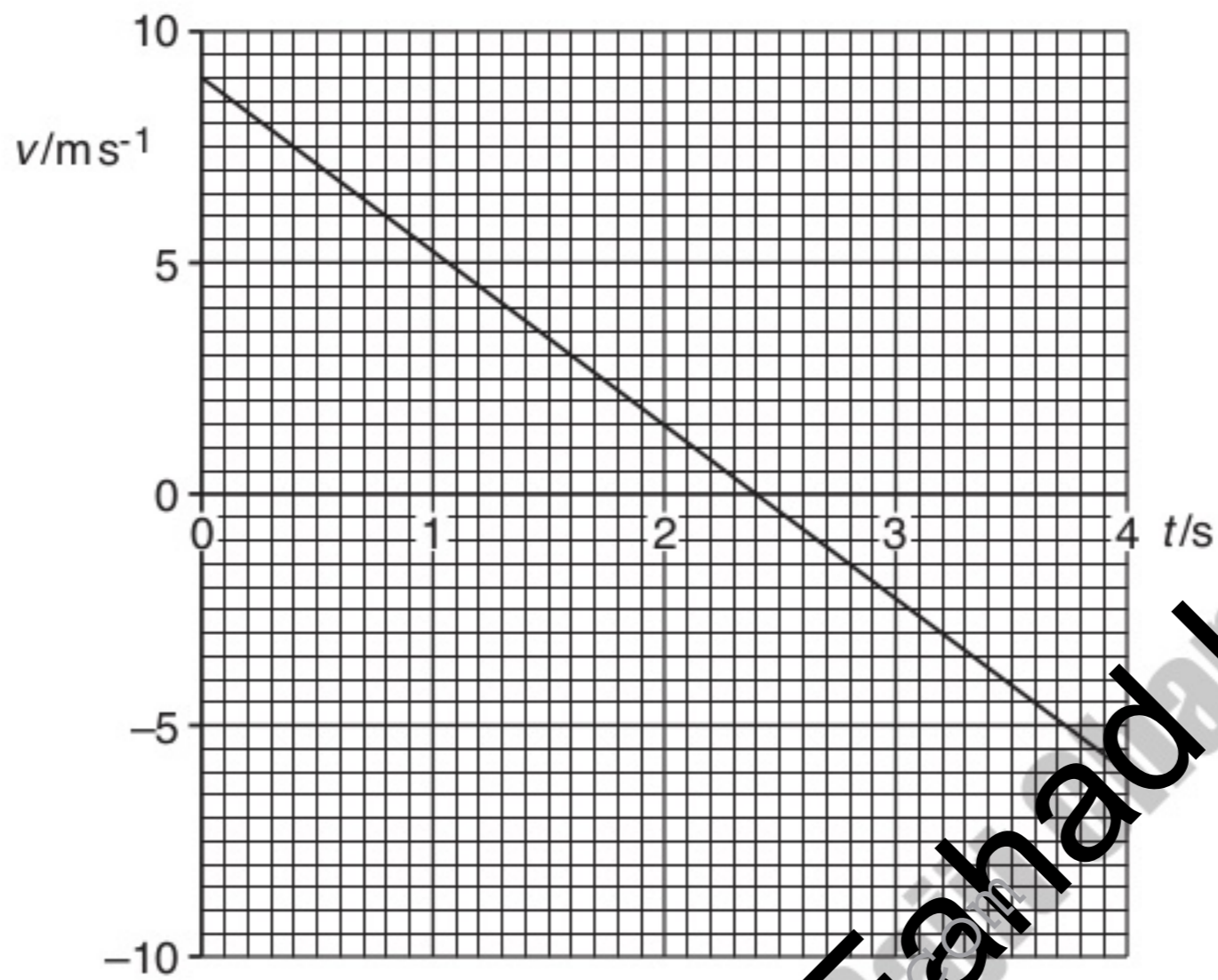

Fig. 2.1

The sphere lands on a small hill at time $t = 4.0$ s.

- (a) State the time t at which the sphere reaches its maximum height above the planet's surface.

$t = \dots\dots\dots$ s [1]

- (b) Determine the vertical height above the point of projection at which the sphere finally comes to rest on the hill.

height = $\dots\dots\dots$ m [3]

(c) Calculate, for the first 3.5 s of the motion of the sphere,

(i) the change in momentum of the sphere,

change in momentum = N s [2]

(ii) the force acting on the sphere.

force = N [2]

(d) Using your answer in (c)(ii),

(i) state the weight of the sphere,

weight = N [1]

(ii) determine the acceleration of free fall on the surface of Mars.

acceleration = ms⁻² [2]

Compiled and rearranged by Fahad H. Ahmad

- 3 (a) A stone of mass 56g is thrown horizontally from the top of a cliff with a speed of 18ms^{-1} , as illustrated in Fig. 4.1.

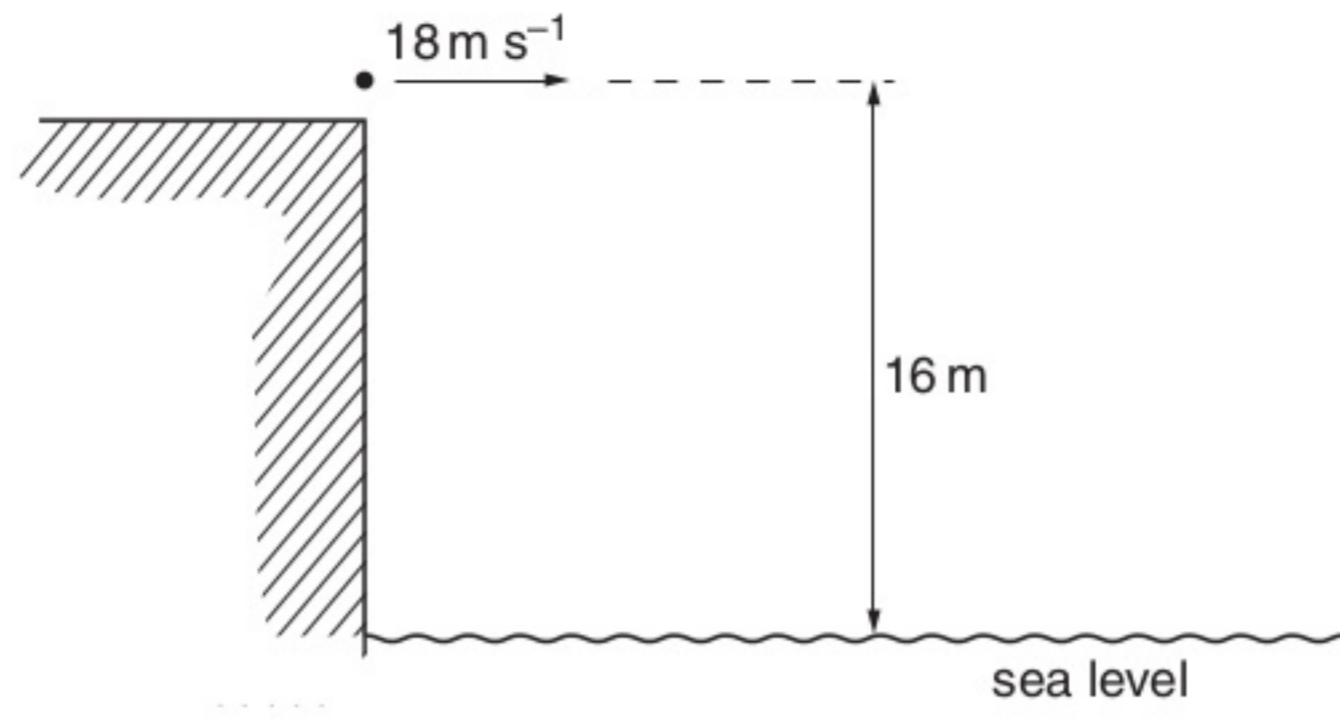

Fig. 4.1

The initial height of the stone above the level of the sea is 16m. Air resistance may be neglected.

- (i) Calculate the change in gravitational potential energy of the stone as a result of falling through 16m.

change = J [2]

- (ii) Calculate the total kinetic energy of the stone as it reaches the sea.

kinetic energy = J [3]

Compiled and rearranged by Fahad H. Ahmad

(b) Use your answer in (a)(ii) to show that the speed of the stone as it hits the water is approximately 25 m s^{-1} .

[1]

(c) State the horizontal velocity of the stone as it hits the water.

horizontal velocity = m s^{-1} [1]

(d) (i) On the grid of Fig. 4.2, draw a vector diagram to represent the horizontal velocity and the resultant velocity of the stone as it hits the water. [1]

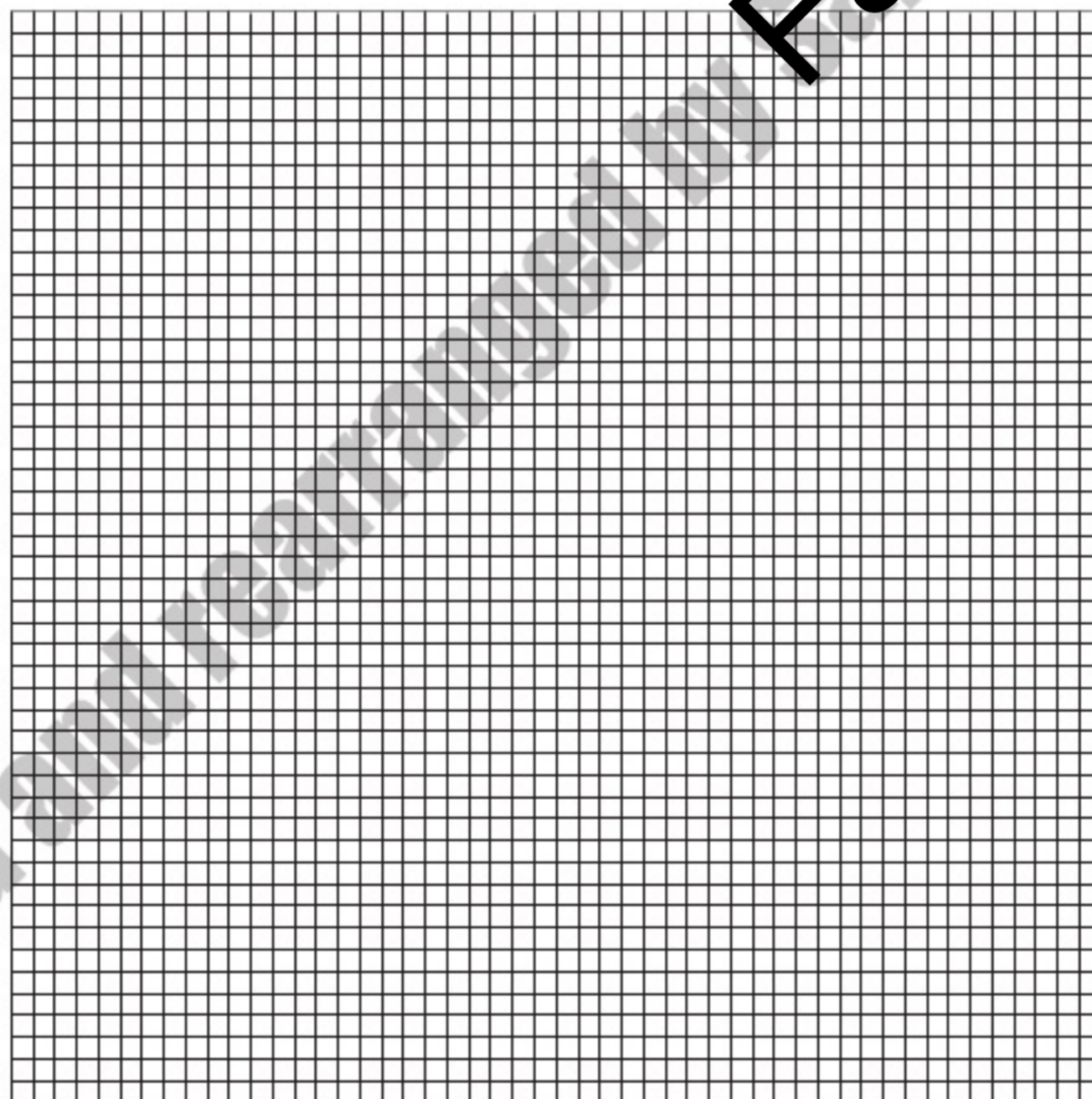

Fig. 4.2

(ii) Use your vector diagram to determine the angle with the horizontal at which the stone hits the water.

angle = $^{\circ}$ [2]

- 4 A ball B of mass 1.2 kg travelling at constant velocity collides head-on with a stationary ball S of mass 3.6 kg, as shown in Fig. 2.1.



Fig. 2.1

Frictional forces are negligible.

The variation with time t of the velocity v of ball B before, during and after colliding with ball S is shown in Fig. 2.2.

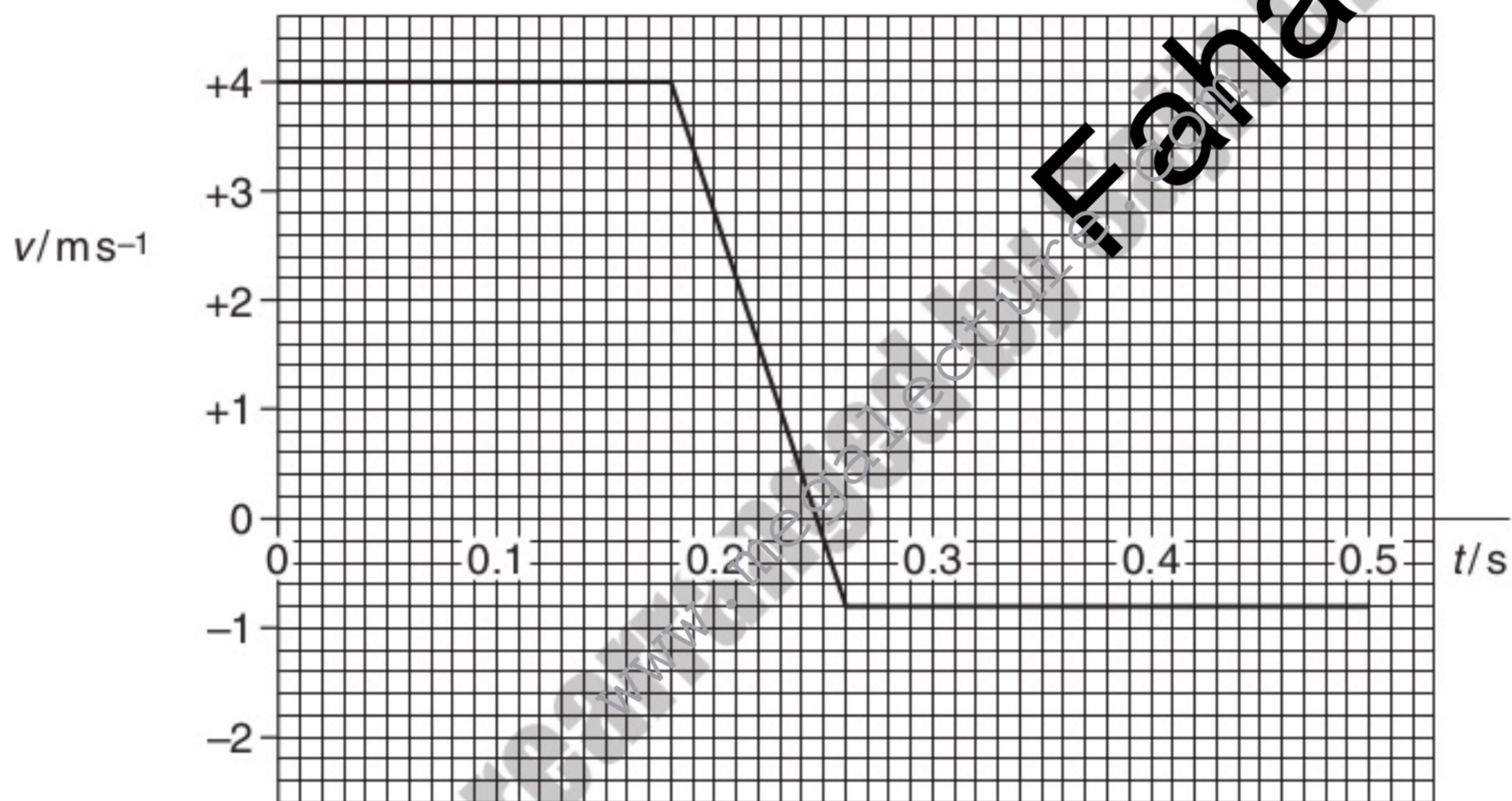

Fig. 2.2

- (a) State the significance of positive and negative values for v in Fig. 2.2.

.....

..... [1]

(b) Use Fig. 2.2 to determine, for ball B during the collision with ball S,

(i) the change in momentum of ball B,

change in momentum = Ns [3]

(ii) the magnitude of the force acting on ball B.

force = N [3]

(c) Calculate the speed of ball S after the collision.

speed = ms^{-1} [2]

Compiled and rearranged by Fahad H. Ahmad

(d) Using your answer in (c) and information from Fig. 2.2, deduce quantitatively whether the collision is elastic or inelastic.

For
Examiner's
Use

.....

..... [2]

Compiled and rearranged by Fahad H. Ahmad
www.megalecture.com

- 5 A ball falls from rest onto a flat horizontal surface. Fig. 3.1 shows the variation with time t of the velocity v of the ball as it approaches and rebounds from the surface.

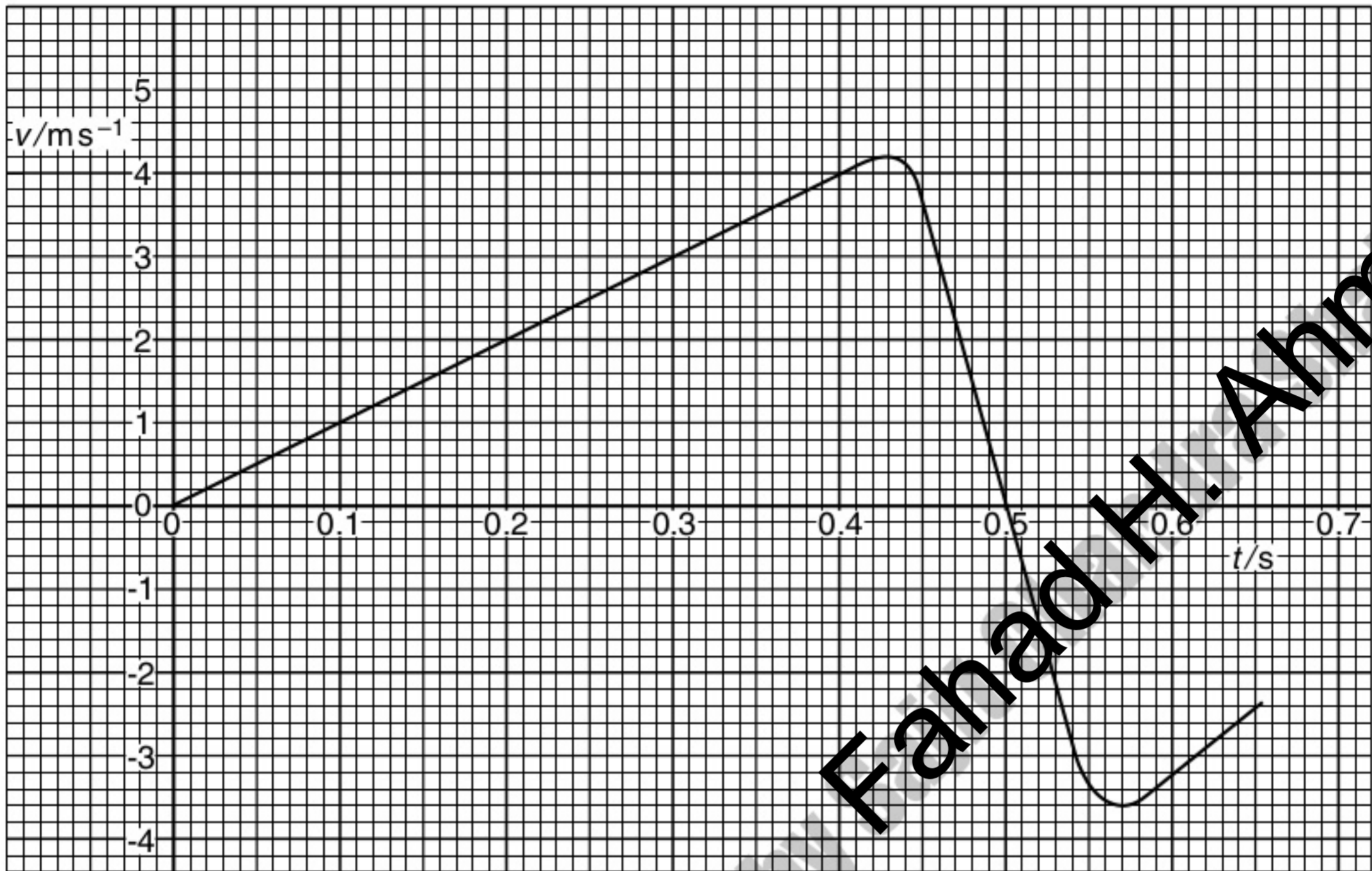

Fig. 3.1

Use data from Fig. 3.1 to determine

- (a) the distance travelled by the ball during the first 0.40 s,

distance = m [2]

(b) the change in momentum of the ball, of mass 45 g, during contact of the ball with the surface,

change = N [4]

(c) the average force acting on the ball during contact with the surface.

force = N [2]

Compiled and rearranged by Fahad H. Ahmad
www.megalecture.com

- 6 A girl stands at the top of a cliff and throws a ball vertically upwards with a speed of 12 m s^{-1} , as illustrated in Fig. 3.1.

For
Examiner's
Use

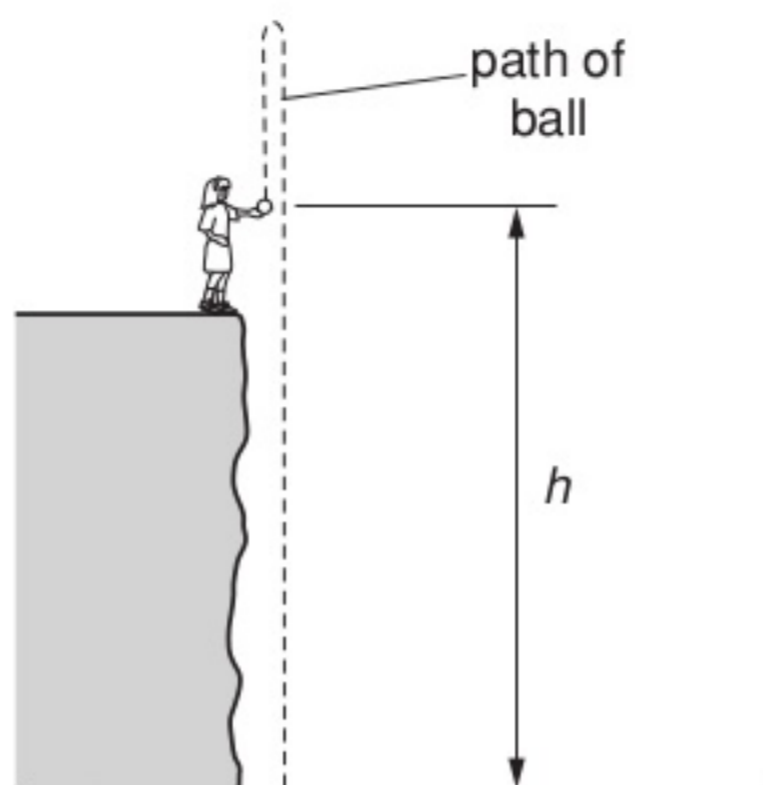

Fig. 3.1

At the time that the girl throws the ball, her hand is a height h above the horizontal ground at the base of the cliff.

The variation with time t of the speed v of the ball is shown in Fig. 3.2.

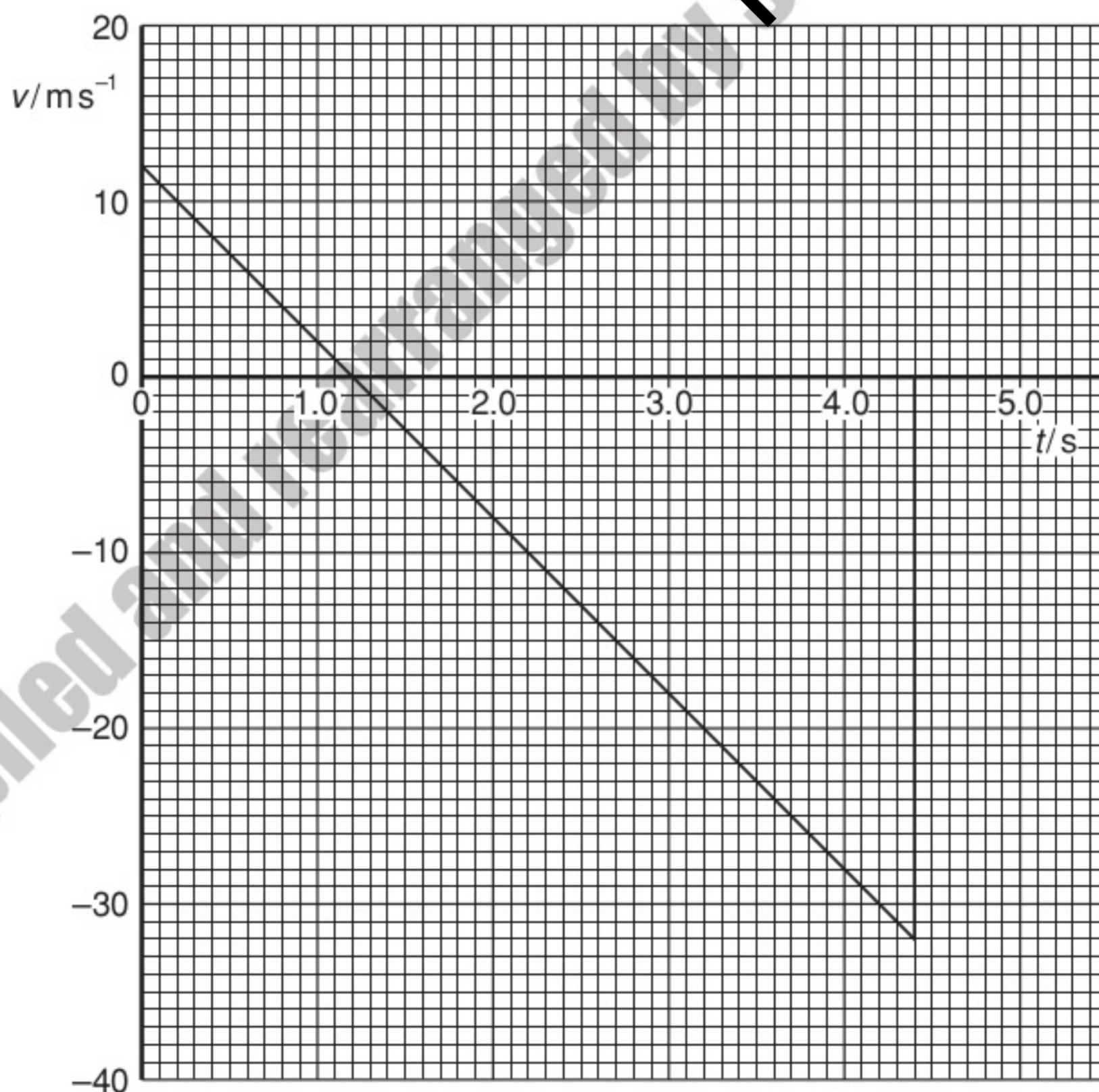

Fig. 3.2

Speeds in the upward direction are shown as being positive. Speeds in the downward direction are negative.

For
Examiner's
Use

(a) State the feature of Fig. 3.2 that shows that the acceleration is constant.

..... [1]

(b) Use Fig. 3.2 to determine the time at which the ball

(i) reaches maximum height,

time = s

(ii) hits the ground at the base of the cliff.

time = s
[2]

(c) Determine the maximum height above the base of the cliff to which the ball rises.

height = m [3]

(d) The ball has mass 250 g. Calculate the magnitude of the change in momentum of the ball between the time that it leaves the girl's hand to time $t = 4.0$ s.

change = N s [3]

(e) (i) State the principle of conservation of momentum.

.....
.....
..... [2]

For
Examiner's
Use

(ii) Comment on your answer to (d) by reference to this principle.

.....
.....
.....
..... [3]

Compiled and rearranged by Fahad H. Ahmad

- 7 A trolley of mass 930 g is held on a horizontal surface by means of two springs, as shown in Fig. 4.1.

For
Examiner's
Use

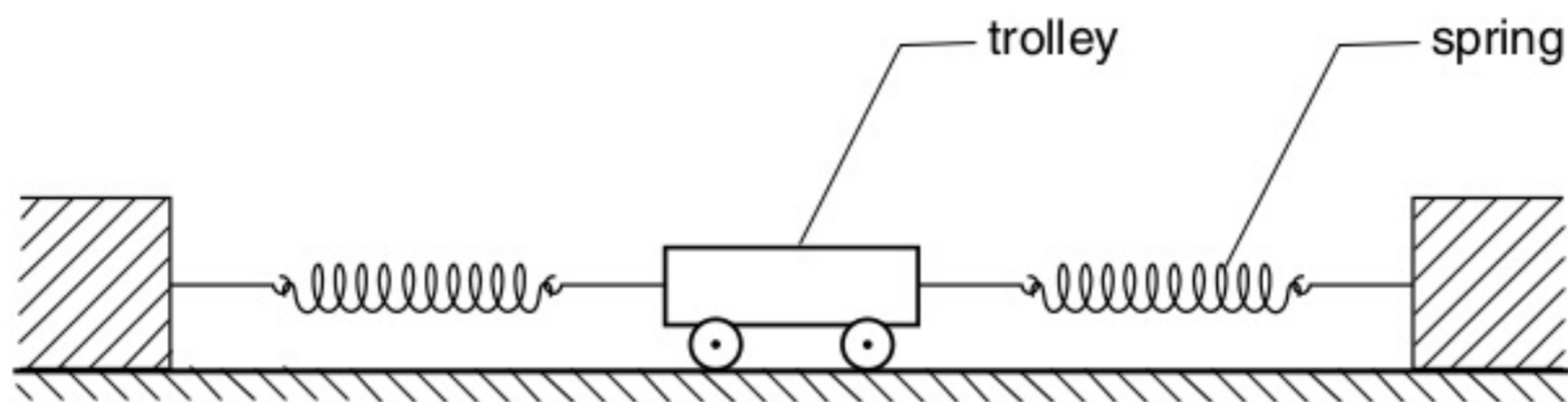

Fig. 4.1

The variation with time t of the speed v of the trolley for the first 0.60 s of its motion is shown in Fig. 4.2.

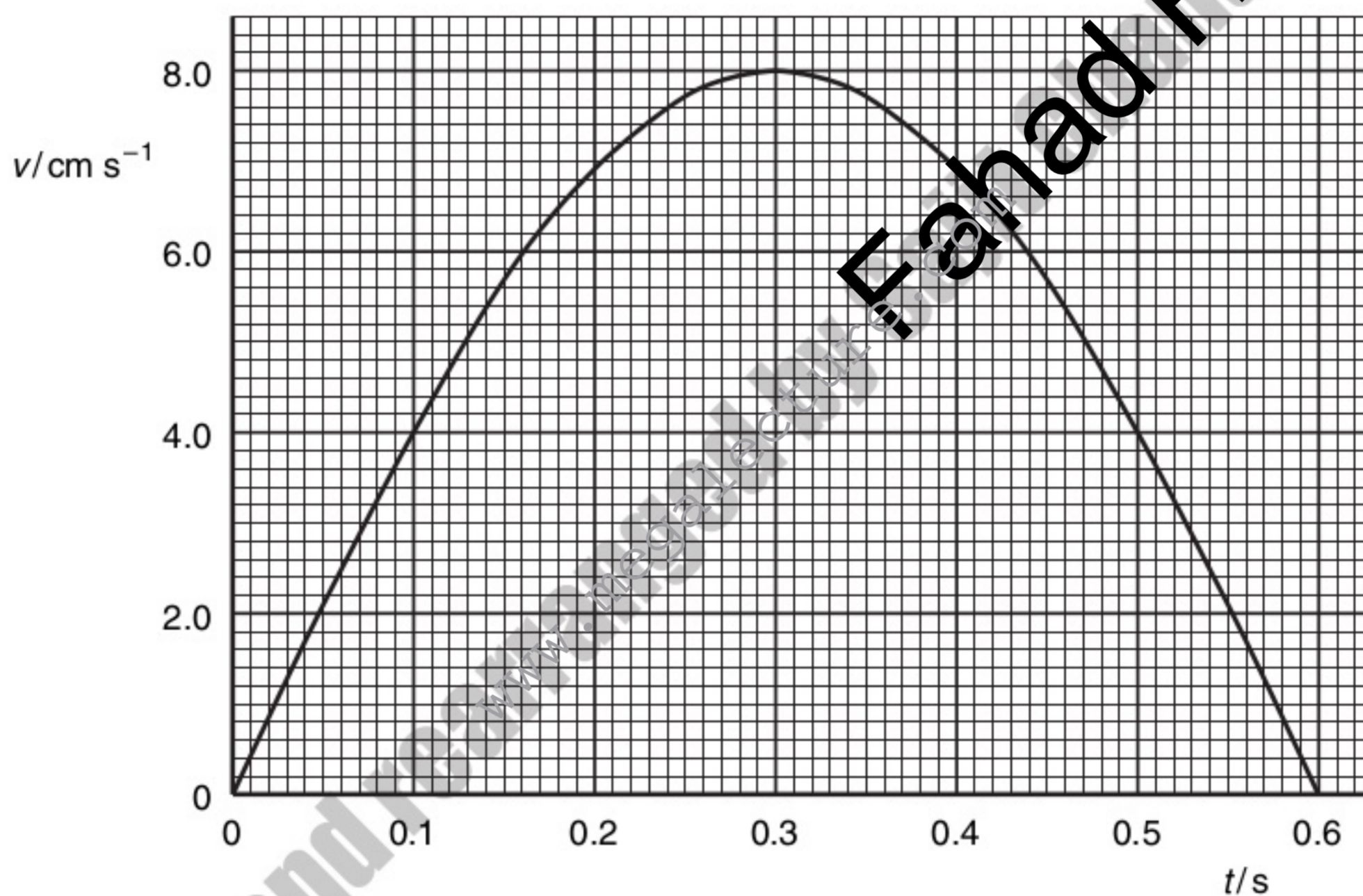

Fig. 4.2

- (a) Use Fig. 4.2 to determine
(i) the initial acceleration of the trolley,

acceleration = m s^{-2} [2]

(ii) the distance moved during the first 0.60 s of its motion.

For
Examiner's
Use

distance = m [3]

(b) (i) Use your answer to (a)(i) to determine the resultant force acting on the trolley at time $t = 0$.

force = N [2]

(ii) Describe qualitatively the variation with time of the resultant force acting on the trolley during the first 0.60 s of its motion.

.....

.....

.....

..... [3]

Compiled and rearranged by Fahad H. Ahmad

8 A stone on a string is made to travel along a horizontal circular path, as shown in Fig. 3.1.

For
Examiner's
Use

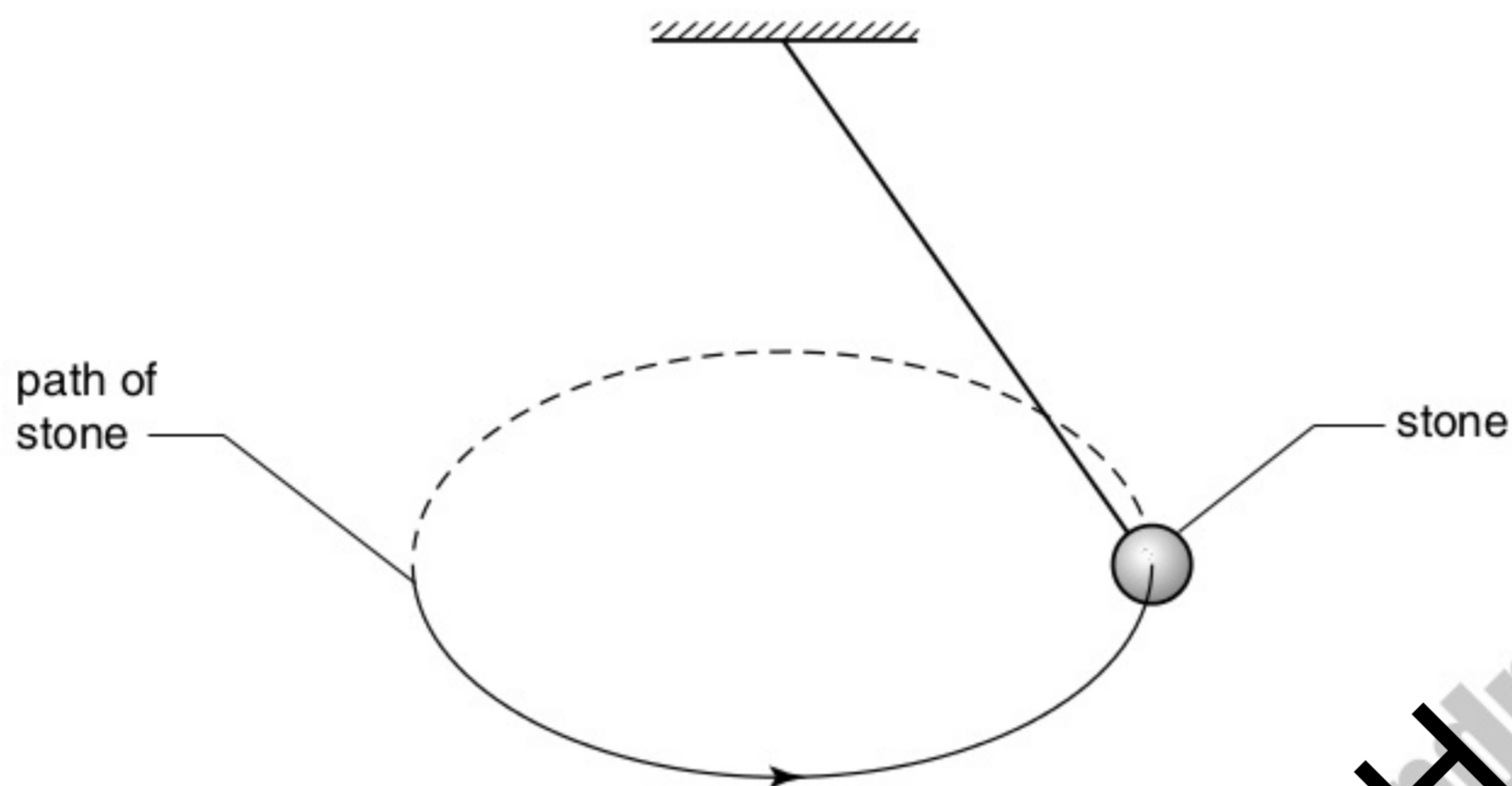

Fig. 3.1

The stone has a constant speed.

(a) Define *acceleration*.

.....
..... [1]

(b) Use your definition to explain whether the stone is accelerating.

.....
.....
..... [2]

Compiled and researched by Fahad H. Ahmad

(c) The stone has a weight of 5.0 N. When the string makes an angle of 35° to the vertical, the tension in the string is 6.1 N, as illustrated in Fig. 3.2.

For
Examiner's
Use

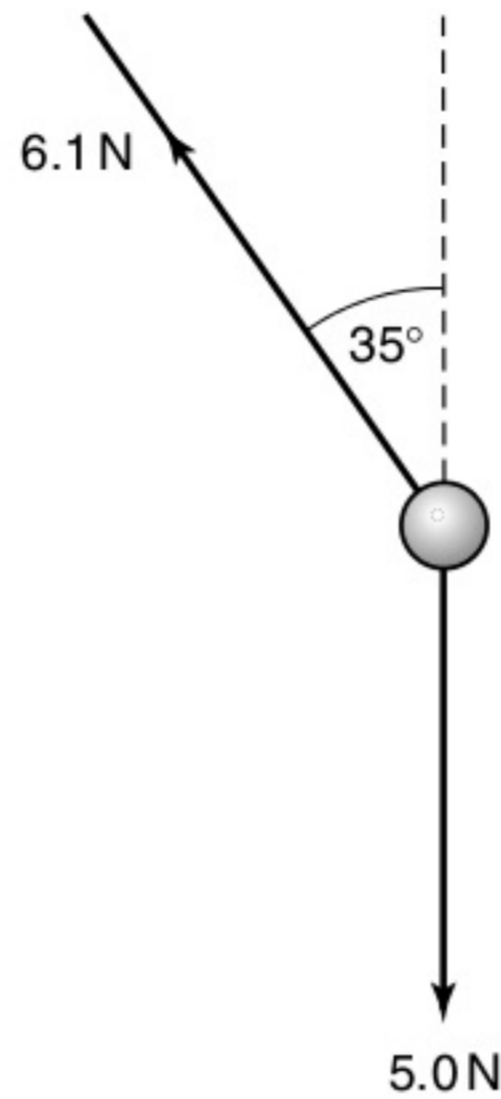

Fig. 3.2

Determine the resultant force acting on the stone in the position shown.

magnitude of force = N

direction of force..... [4]

9 A student investigates the speed of a trolley as it rolls down a slope, as illustrated in Fig. 2.1.

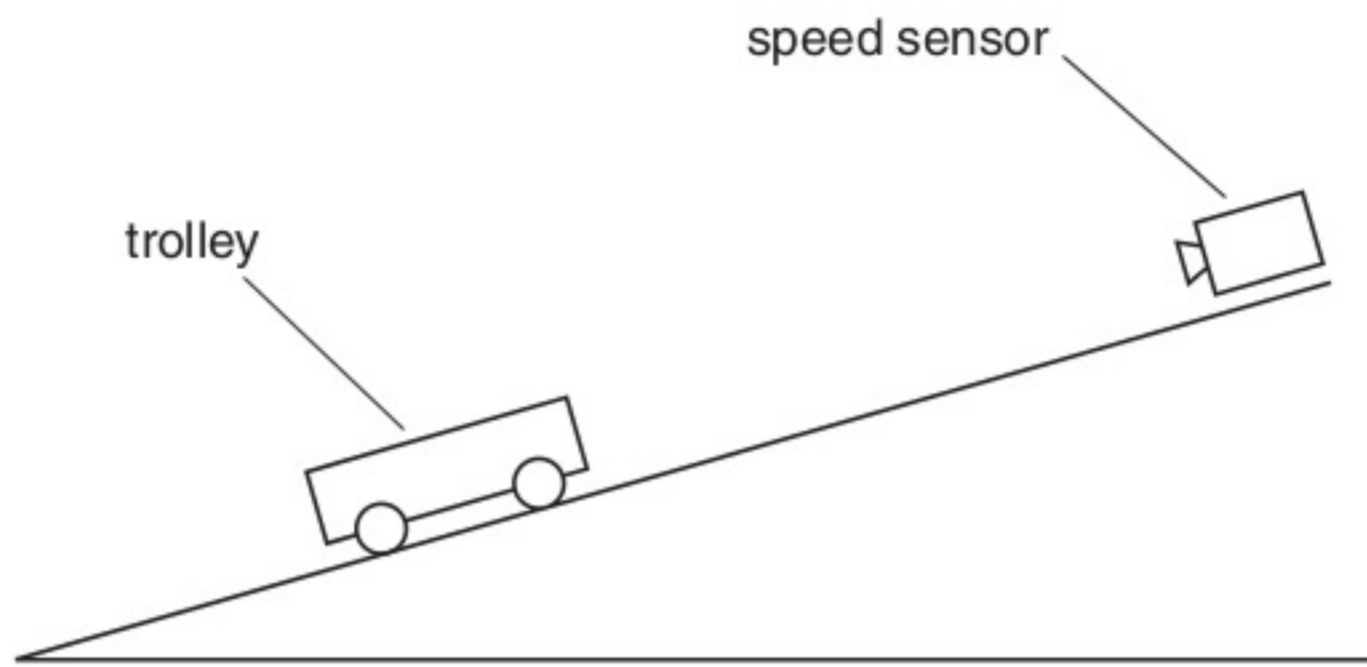

Fig. 2.1

The speed v of the trolley is measured using a speed sensor for different values of the time t that the trolley has moved from rest down the slope.

Fig. 2.2 shows the variation with t of v .

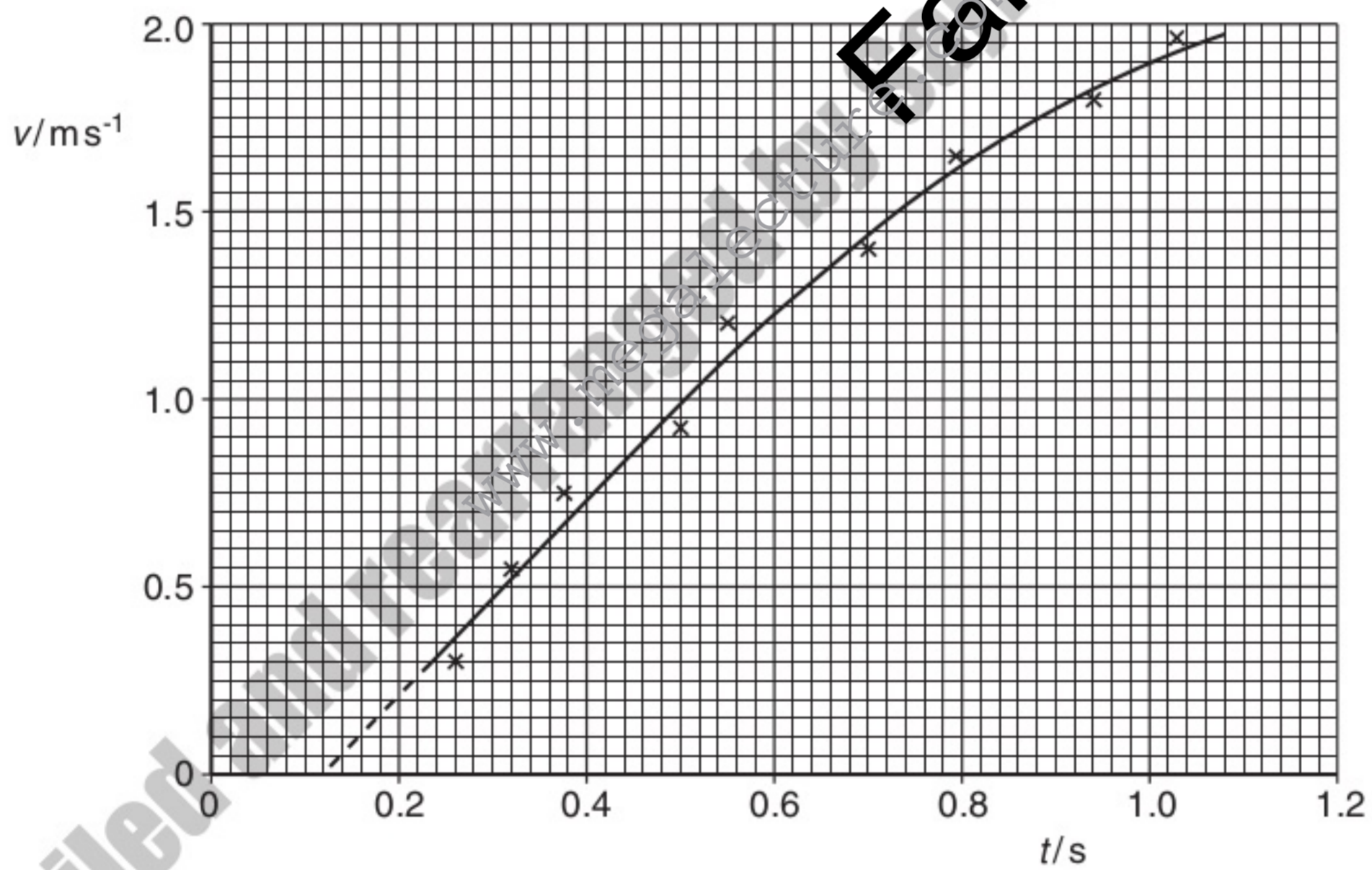

Fig. 2.2

- (a) Use Fig. 2.2 to determine the acceleration of the trolley at the point on the graph where $t = 0.80$ s.

For Examiner's Use

acceleration = m s^{-2} [4]

- (b) (i) State whether the acceleration is increasing or decreasing for values of t greater than 0.6 s. Justify your answer by reference to Fig. 2.2.

.....

 [2]

- (ii) Suggest an explanation for this change in acceleration.

.....
 [1]

- (c) Name the feature of Fig. 2.2 that indicates the presence of

- (i) random error,

.....
 [1]

- (ii) systematic error.

.....
 [1]

10 Francium-208 is radioactive and emits α -particles with a kinetic energy of $1.07 \times 10^{-12} \text{ J}$ to form nuclei of astatine, as illustrated in Fig. 3.1.

For
Examiner's
Use

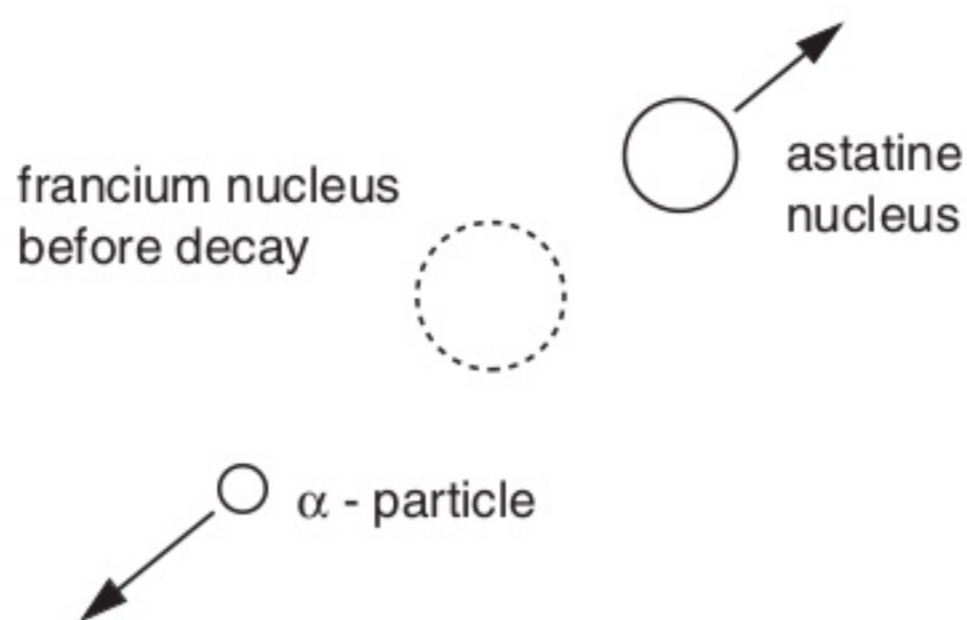

Fig. 3.1

(a) State the nature of an α -particle.

.....
 [1]

(b) Show that the initial speed of an α -particle after the decay of a francium nucleus is approximately $1.8 \times 10^7 \text{ m s}^{-1}$.

.....
 [2]

(c) (i) State the principle of conservation of linear momentum.

.....
 [2]

- (ii) The Francium-208 nucleus is stationary before the decay. Estimate the speed of the astatine nucleus immediately after the decay.

For
Examiner's
Use

speed = m s⁻¹ [3]

- (d) Close examination of the decay of the francium nucleus indicates that the astatine nucleus and the α -particle are not ejected exactly in opposite directions.

Suggest an explanation for this observation.

.....
.....
..... [2]

Compiled and rearranged by Fahad H. Ahmad

- 11 A girl G is riding a bicycle at a constant velocity of 3.5 ms^{-1} . At time $t = 0$, she passes a boy B sitting on a bicycle that is stationary, as illustrated in Fig. 2.1.

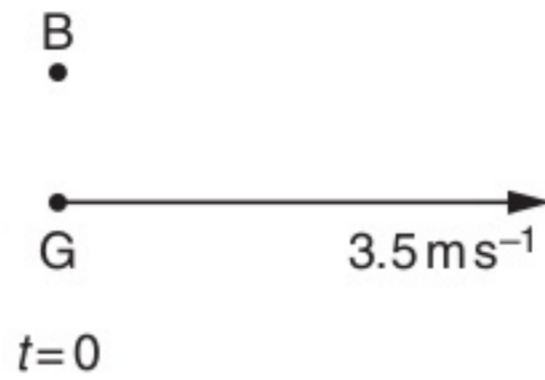

Fig. 2.1

At time $t = 0$, the boy sets off to catch up with the girl. He accelerates uniformly from time $t = 0$ until he reaches a speed of 5.6 ms^{-1} in a time of 5.0 s . He then continues at a constant speed of 5.6 ms^{-1} . At time $t = T$, the boy catches up with the girl. T is measured in seconds.

- (a) State, in terms of T , the distance moved by the girl before the boy catches up with her.

distance = m [1]

- (b) For the boy, determine

- (i) the distance moved during his acceleration,

distance = m [2]

- (ii) the distance moved during the time that he is moving at constant speed.
Give your answer in terms of T .

distance = m [1]

- (c) Use your answers in (a) and (b) to determine the time T taken for the boy to catch up with the girl.

$T = \dots\dots\dots$ s [2]

- (d) The boy and the bicycle have a combined mass of 67 kg.

- (i) Calculate the force required to cause the acceleration of the boy.

force = $\dots\dots\dots$ N [3]

- (ii) At a speed of 4.5 ms^{-1} , the total resistive force acting on the boy and bicycle is 23 N.
Determine the output power of the boy's legs at this speed.

power = $\dots\dots\dots$ W [2]

Compiled and rearranged by Fahad H. Ahmad

12 A car is travelling along a straight road at speed v . A hazard suddenly appears in front of the car. In the time interval between the hazard appearing and the brakes on the car coming into operation, the car moves forward a distance of 29.3 m. With the brakes applied, the front wheels of the car leave skid marks on the road that are 12.8 m long, as illustrated in Fig. 2.1.

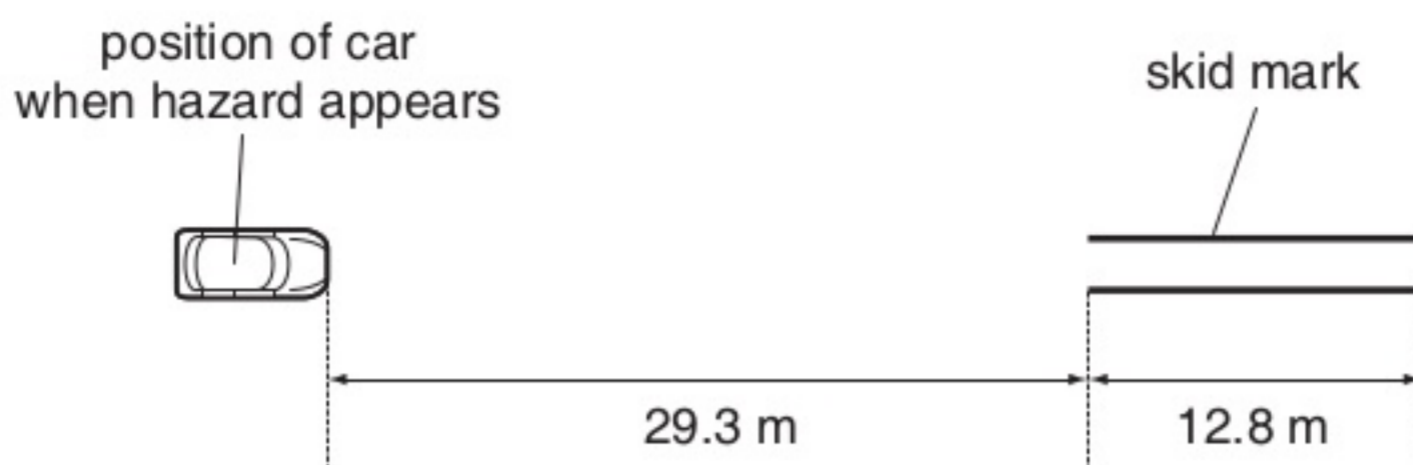

Fig. 2.1

It is estimated that, during the skid, the magnitude of the deceleration of the car is $0.85g$, where g is the acceleration of free fall.

(a) Determine

(i) the speed v of the car before the brakes are applied

$v = \dots\dots\dots \text{ms}^{-1}$ [2]

(ii) the time interval between the hazard appearing and the brakes being applied.

time = $\dots\dots\dots$ s [2]

Compiled and rearranged by Fahad H. Ahmad

(b) The legal speed limit on the road is 60km per hour.
Use both of your answers in **(a)** to comment on the standard of the driving of the car.

*For
Examiner's
Use*

.....

.....

.....

..... [3]

Compiled and rearranged by Fahad H. Ahmad

13 A sky-diver jumps from a high-altitude balloon.

(a) Explain briefly why the acceleration of the sky-diver

(i) decreases with time,

.....

(ii) is 9.8 ms^{-2} at the start of the jump.

.....

[1]

(b) The variation with time t of the vertical speed v of the sky-diver is shown in Fig. 2.1.

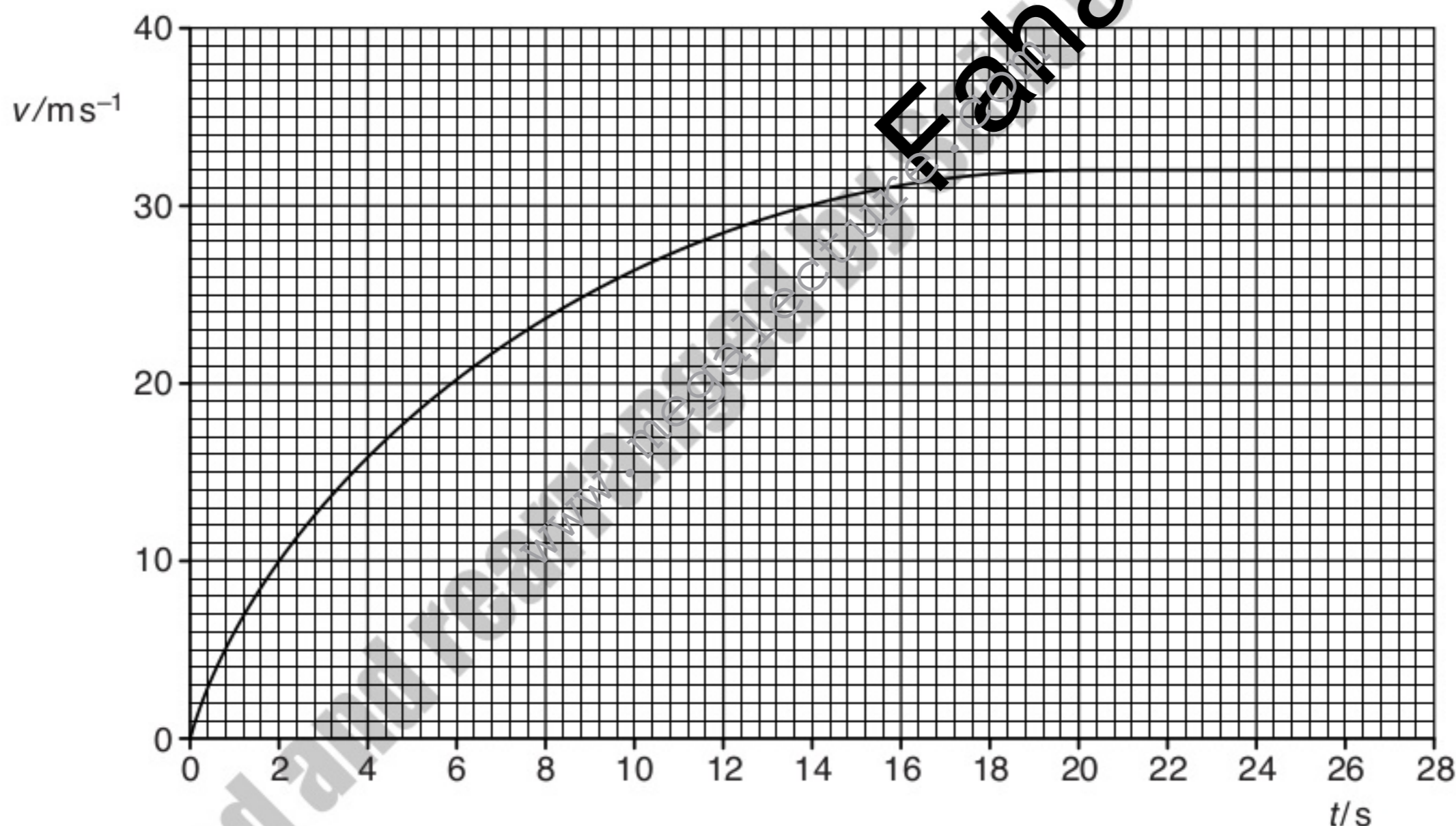

Fig. 2.1

For
Examiner's
Use

Use Fig. 2.1 to determine the magnitude of the acceleration of the sky-diver at time $t = 6.0$ s.

For
Examiner's
Use

acceleration = [3]

(c) The sky-diver and his equipment have a total mass of 90 kg.

(i) Calculate, for the sky-diver and his equipment,

1. the total weight,

weight = N [1]

2. the accelerating force at time $t = 6.0$ s.

force = N [1]

(ii) Use your answers in (i) to determine the total resistive force acting on the sky-diver at time $t = 6.0$ s.

force = N [1]

Compiled and rearranged by Fahad H. Ahmad

14 A stationary nucleus of mass 220u undergoes radioactive decay to produce a nucleus D of mass 216u and an α -particle of mass 4u, as illustrated in Fig. 3.1.

For
Examiner's
Use

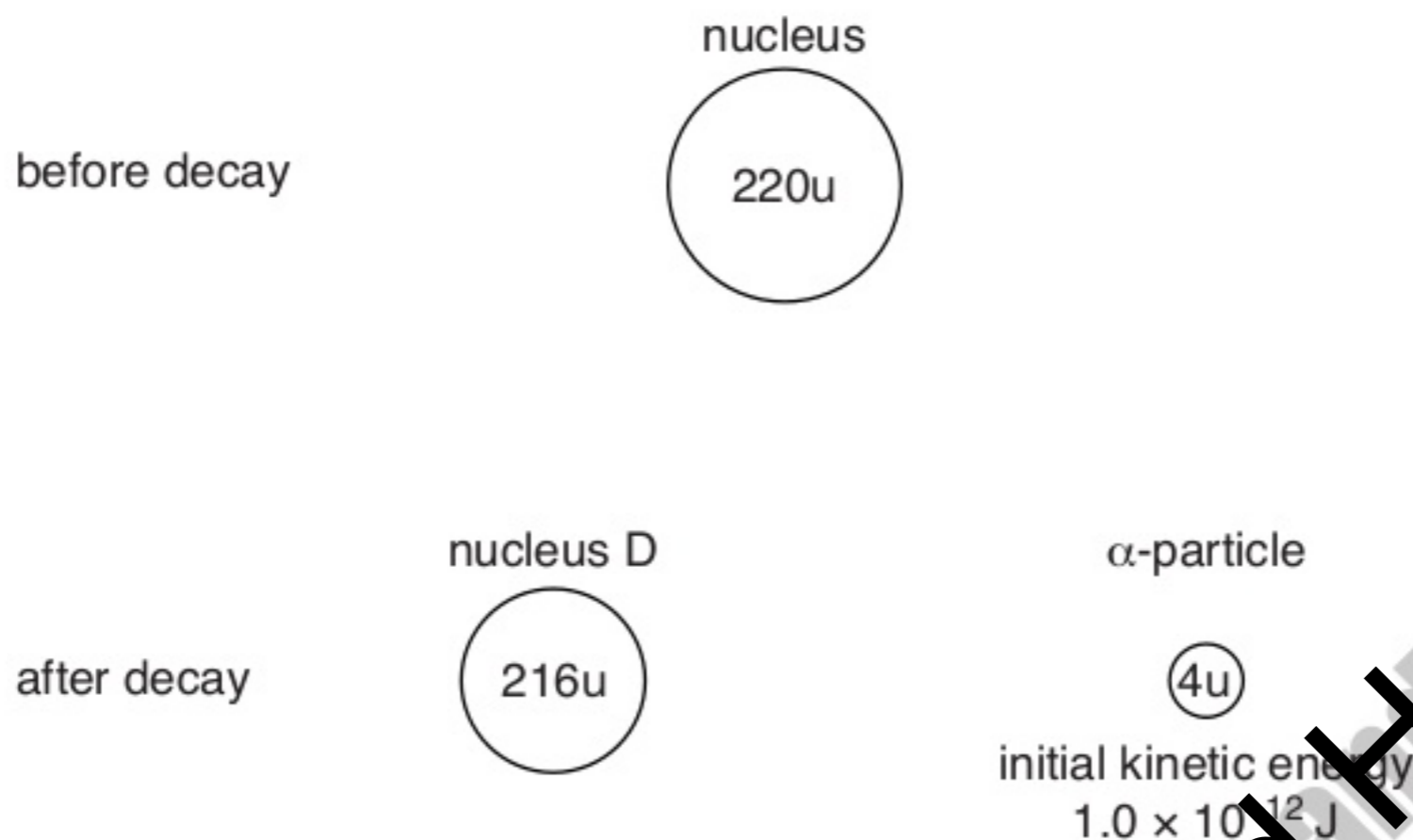

Fig. 3.1

The initial kinetic energy of the α -particle is $1.0 \times 10^{-12} \text{ J}$.

(a) (i) State the law of conservation of linear momentum.

.....

 [2]

(ii) Explain why the initial velocities of the nucleus D and the α -particle must be in opposite directions.

.....

 [2]

(b) (i) Show that the initial speed of the α -particle is $1.7 \times 10^7 \text{ ms}^{-1}$.

[2]

(ii) Calculate the initial speed of nucleus D.

For
Examiner's
Use

speed = m s^{-1} [2]

(c) The range in air of the emitted α -particle is 4.5 cm.
Calculate the average deceleration of the α -particle as it is stopped by the air.

deceleration = m s^{-2} [2]

Compiled and rearranged by Fahad H. Ahmad

15 A small ball is thrown horizontally with a speed of 4.0 m s^{-1} . It falls through a vertical height of 1.96 m before bouncing off a horizontal plate, as illustrated in Fig. 3.1.

For
Examiner's
Use

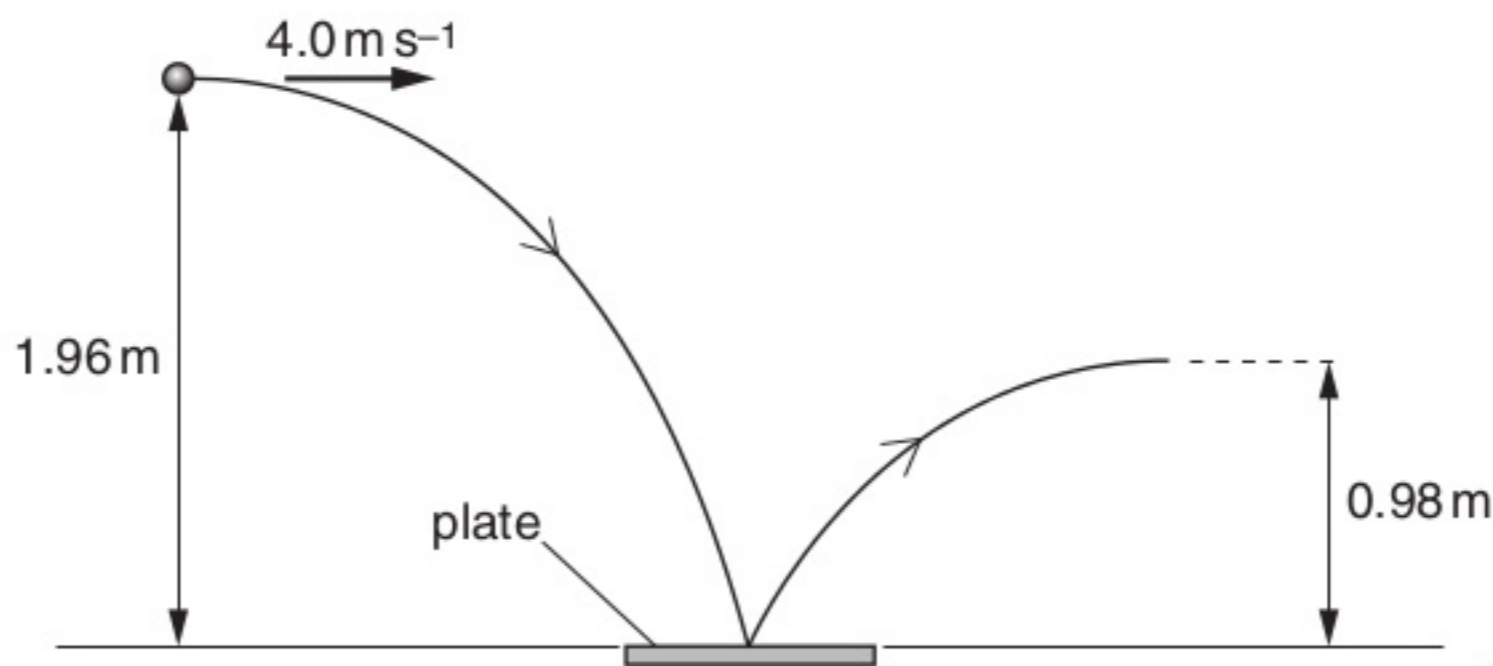

Fig. 3.1

Air resistance is negligible.

(a) For the ball, as it hits the horizontal plate,

(i) state the magnitude of the horizontal component of its velocity,

horizontal velocity = m s^{-1} [1]

(ii) show that the vertical component of the velocity is 6.2 m s^{-1} .

[1]

(b) The components of the velocity in (a) are both vectors.

Complete Fig. 3.2 to draw a vector diagram, to scale, to determine the velocity of the ball as it hits the horizontal plate.

For
Examiner's
Use



Fig. 3.2

velocity =ms⁻¹

at ° to the vertical

[3]

(c) After bouncing on the plate, the ball rises to a vertical height of 0.98 m.

(i) Calculate the vertical component of the velocity of the ball as it leaves the plate.

vertical velocity = ms⁻¹ [2]

Compiled and rearranged by Fahad H. Ahmad

(ii) The ball of mass 34 g is in contact with the plate for a time of 0.12 s.

Use your answer in (c)(i) and the data in (a)(ii) to calculate, for the ball as it bounces on the plate,

For
Examiner's
Use

1. the change in momentum,

change = kg m s^{-1} [3]

2. the magnitude of the average force exerted by the plate on the ball due to this momentum change.

force = N [2]

Compiled and rearranged by Fahad H. Ahmad

16 A steel ball of mass 73 g is held 1.6 m above a horizontal steel plate, as illustrated in Fig. 4.1.

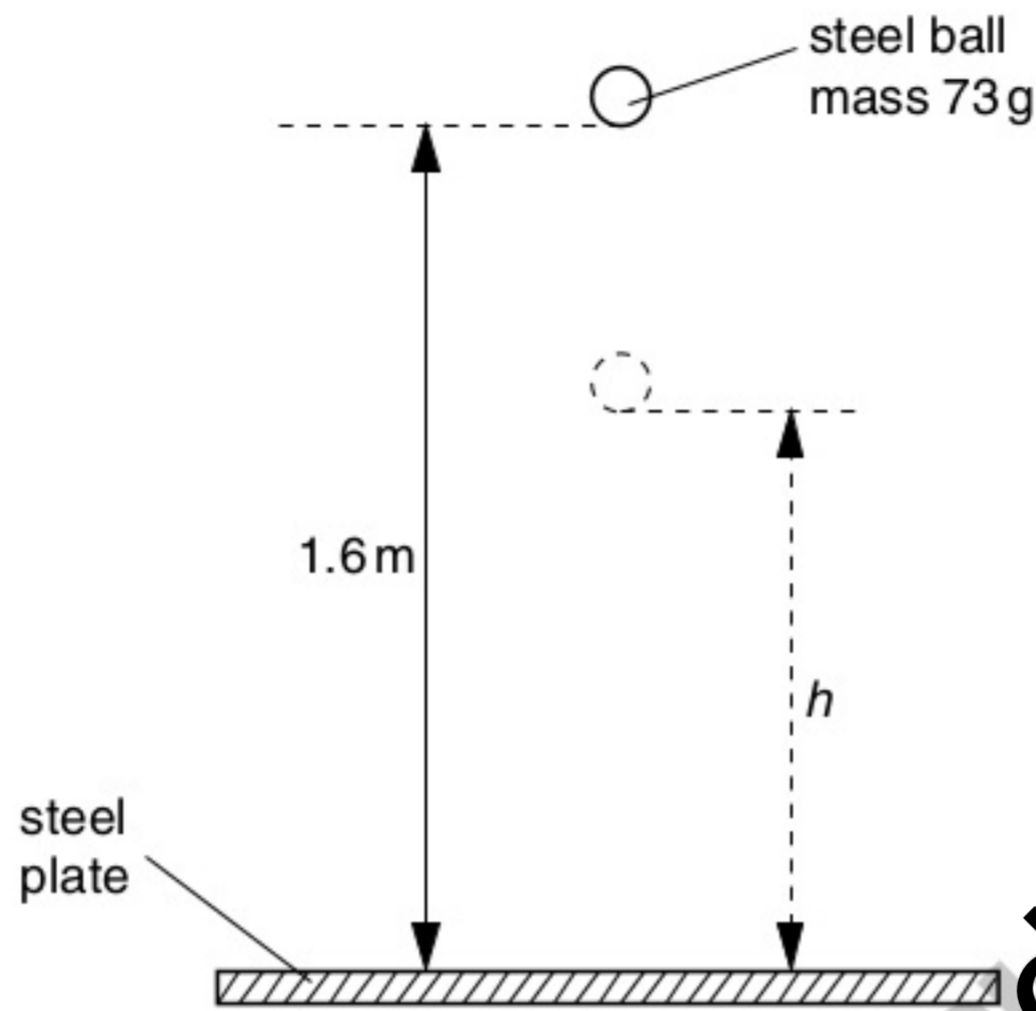

Fig. 4.1

The ball is dropped from rest and it bounces on the plate, reaching a height h .

(a) Calculate the speed of the ball as it reaches the plate.

speed = m s^{-1} [2]

(b) As the ball loses contact with the plate after bouncing, the kinetic energy of the ball is 90% of that just before bouncing. Calculate

(i) the height h to which the ball bounces,

$h =$ m

(ii) the speed of the ball as it leaves the plate after bouncing.

speed = m s^{-1} [4]

(c) Using your answers to (a) and (b), determine the change in momentum of the ball during the bounce.

change = N s [3]

(d) With reference to the law of conservation of momentum, comment on your answer to (c).

.....
.....
.....[3]

- 17 A ball has mass m . It is dropped onto a horizontal plate as shown in Fig. 4.1.

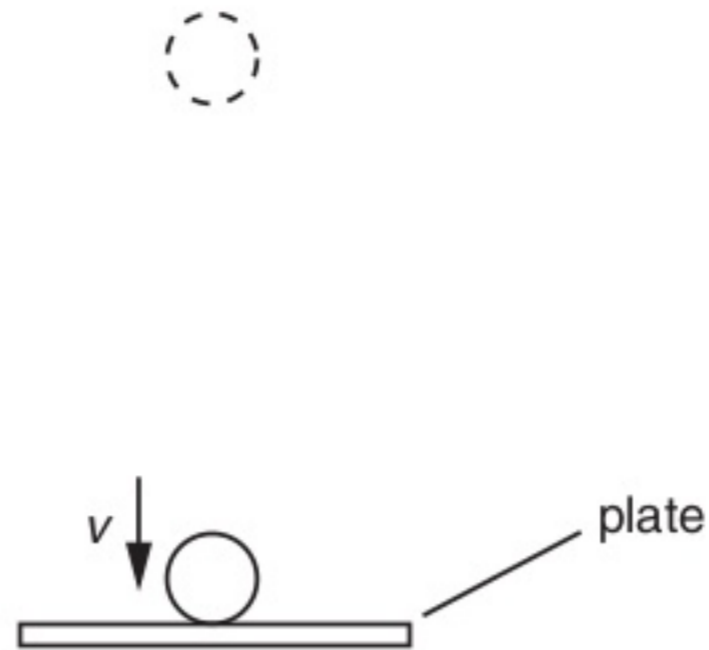

Fig. 4.1

Just as the ball makes contact with the plate, it has velocity v , momentum p and kinetic energy E_k .

- (a) (i) Write down an expression for momentum p in terms of m and v .

.....

- (ii) Hence show that the kinetic energy is given by the expression

$$E_k = \frac{p^2}{2m}.$$

[3]

(b) Just before impact with the plate, the ball of mass 35 g has speed 4.5 m s^{-1} . It bounces from the plate so that its speed immediately after losing contact with the plate is 3.5 m s^{-1} . The ball is in contact with the plate for 0.14 s.

Calculate, for the time that the ball is in contact with the plate,

(i) the average force, in addition to the weight of the ball, that the plate exerts on the ball,

magnitude of force = N
direction of force =
[4]

(ii) the loss in kinetic energy of the ball.

loss = J [2]

(c) State and explain whether linear momentum is conserved during the bounce.

.....
.....
.....
..... [3]

Compiled and rearranged by Fahad H. Ahmad

2 (a) Complete Fig. 2.1 to show whether each of the quantities listed is a vector or a scalar.

	vector / scalar
distance moved
speed
acceleration

Fig. 2.1

[3]

(b) A ball falls vertically in air from rest. The variation with time t of the distance d moved by the ball is shown in Fig. 2.2.

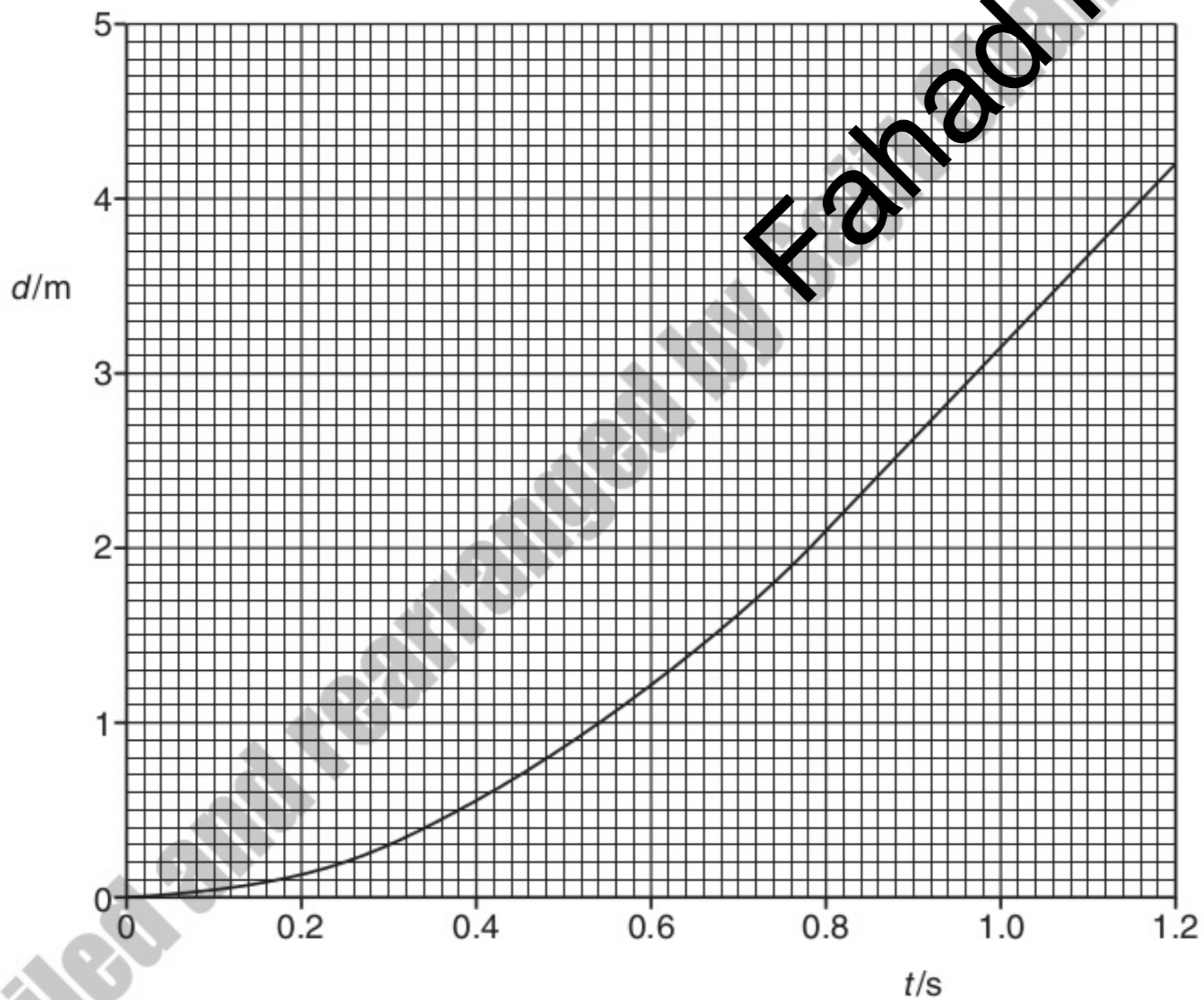

Fig. 2.2

(i) By reference to Fig. 2.2, explain how it can be deduced that

1. the ball is initially at rest,

.....
.....
..... [2]

2. air resistance is not negligible.

.....
..... [1]

(ii) Use Fig. 2.2 to determine the speed of the ball at a time of 0.40 s after it has been released.

speed = m s⁻¹ [2]

(iii) On Fig. 2.2, sketch a graph to show the variation with time *t* of the distance *d* moved by the ball for negligible air resistance. You are not expected to carry out any further calculations. [3]

Compiled and rearranged by Fahad H. Ahmad

2 (a) The distance s moved by an object in time t may be given by the expression

$$s = \frac{1}{2}at^2$$

where a is the acceleration of the object.

State two conditions for this expression to apply to the motion of the object.

1.

.....

2.

.....

[2]

(b) A student takes a photograph of a steel ball of radius 5.0 cm as it falls from rest. The image of the ball is blurred, as illustrated in Fig. 2.1. The image is blurred because the ball is moving while the photograph is being taken.

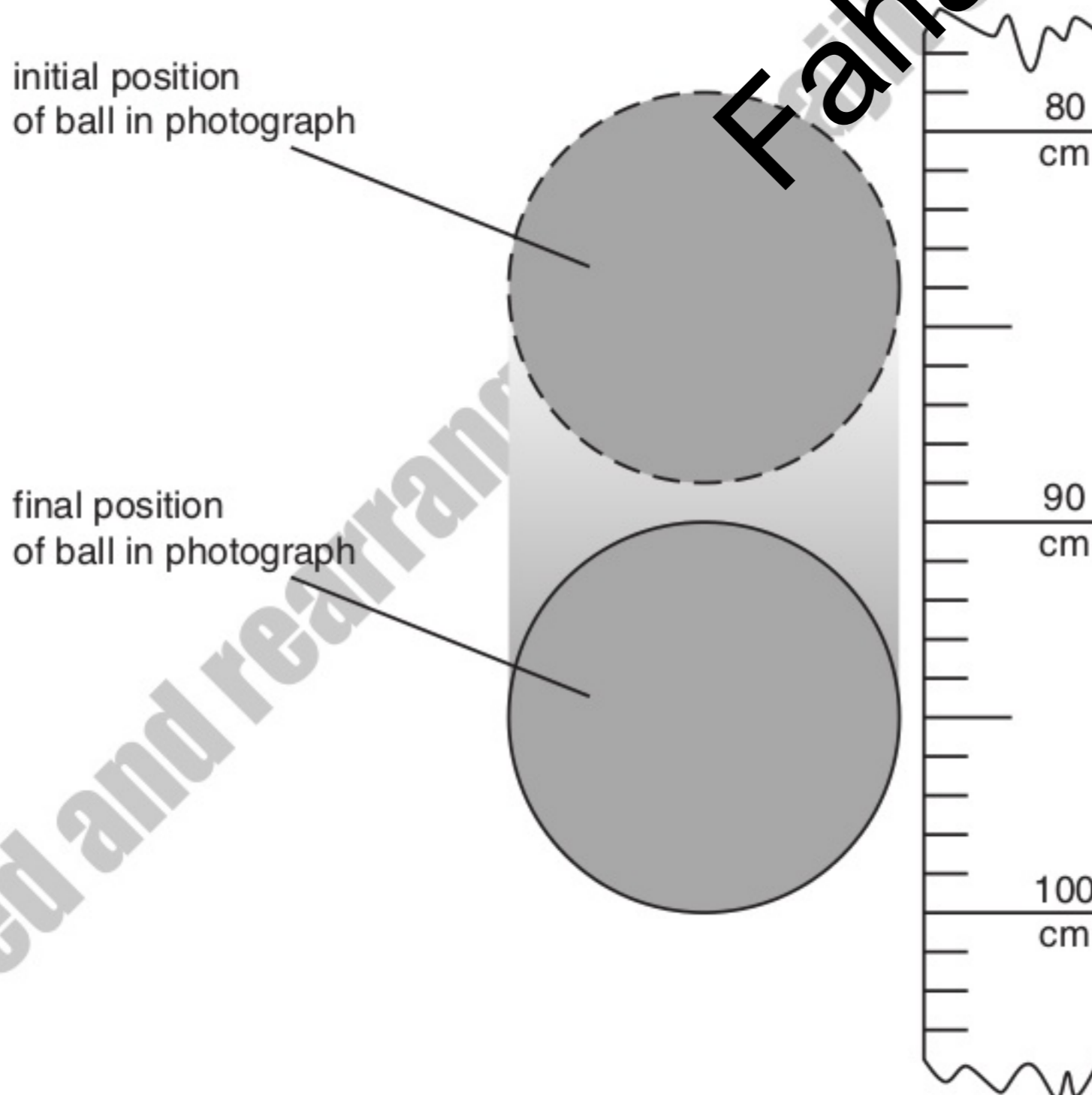

Fig. 2.1

The scale shows the distance fallen from rest by the ball. At time $t = 0$, the top of the ball is level with the zero mark on the scale. Air resistance is negligible.

Calculate, to an appropriate number of significant figures,

- (i) the time the ball falls before the photograph is taken,

time = s [3]

- (ii) the time interval during which the photograph is taken.

time interval = s [3]

- (c) The student in (b) takes a second photograph starting at the same position on the scale. The ball has the same radius but is less dense, so that air resistance is not negligible.

State and explain the changes that will occur in the photograph.

.....

.....

.....

..... [2]

Compiled and read by Fahad H. Ahmad

2 A ball is thrown horizontally from the top of a building, as shown in Fig. 2.1.

For
Examiner's
Use

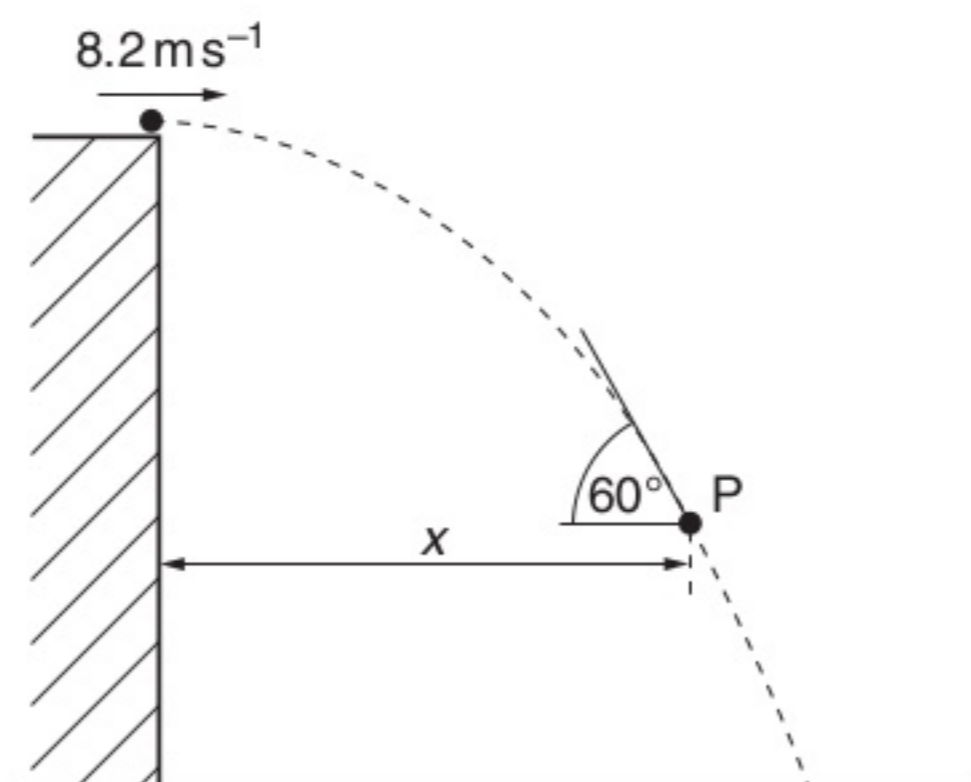

Fig. 2.1

The ball is thrown with a horizontal speed of 8.2 m s^{-1} . The side of the building is vertical. At point P on the path of the ball, the ball is distance x from the building and is moving at an angle of 60° to the horizontal. Air resistance is negligible.

(a) For the ball at point P,

(i) show that the vertical component of its velocity is 14.2 m s^{-1} ,

[2]

(ii) determine the vertical distance through which the ball has fallen,

distance = m [2]

(iii) determine the horizontal distance x .

$x = \dots\dots\dots$ m [2]

(b) The path of the ball in (a), with an initial horizontal speed of 8.2 ms^{-1} , is shown again in Fig. 2.2.

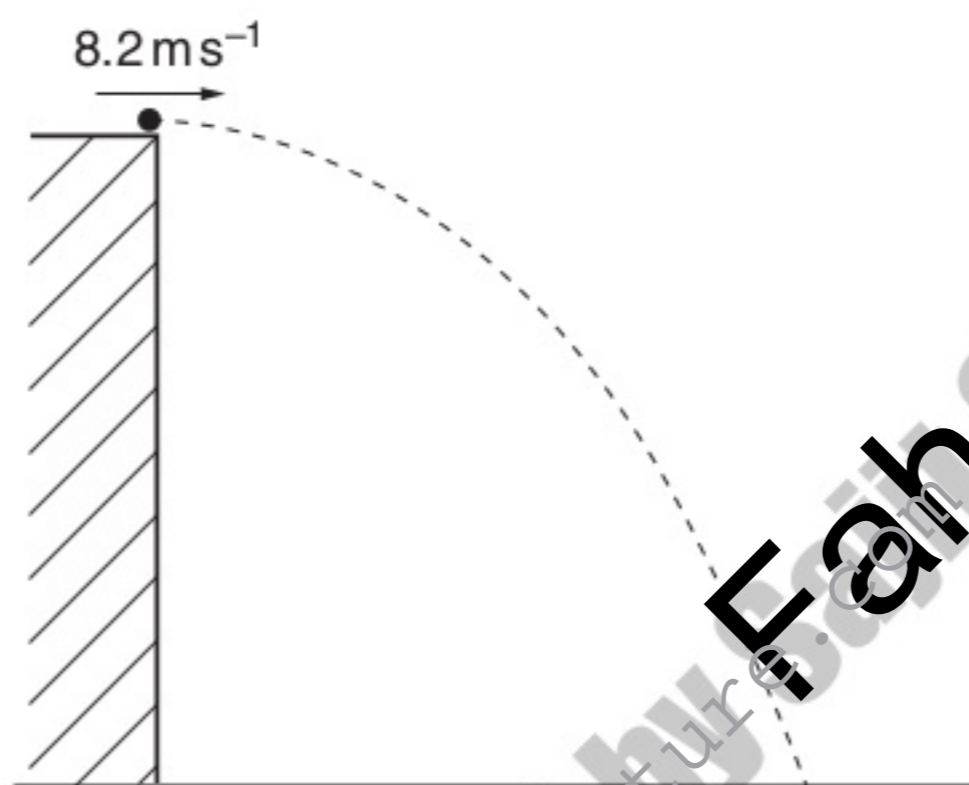

Fig. 2.2

On Fig. 2.2, sketch the new path of the ball for the ball having an initial horizontal speed

- (i) greater than 8.2 ms^{-1} and with negligible air resistance (label this path G), [2]
- (ii) equal to 8.2 ms^{-1} but with air resistance (label this path A). [2]

2 A ball is thrown from a point P, which is at ground level, as illustrated in Fig. 2.1.

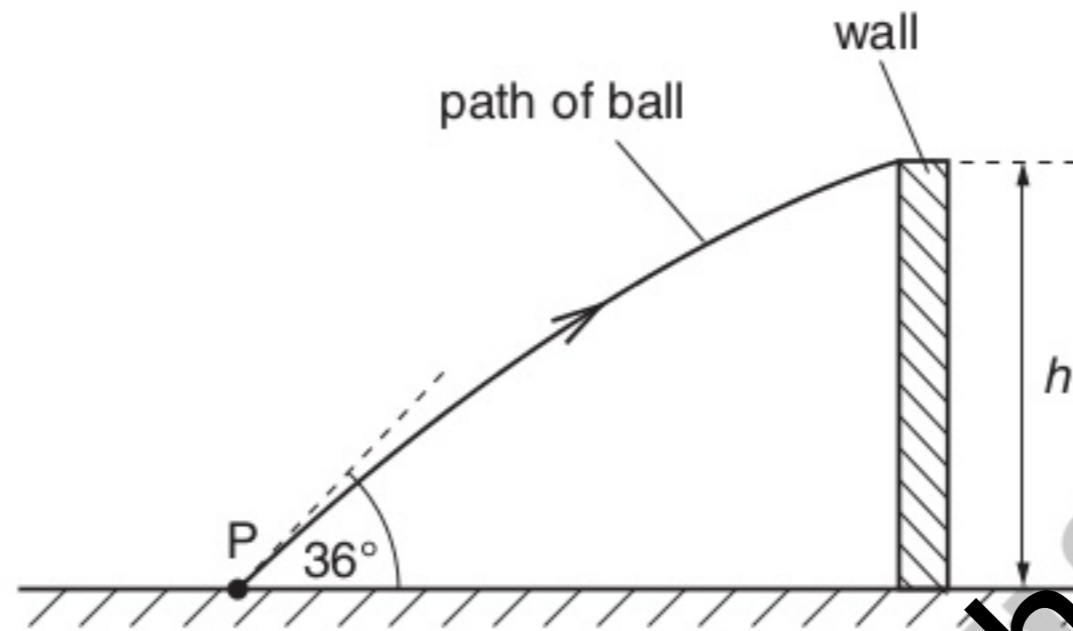

Fig. 2.1

The initial velocity of the ball is 12.4 m s^{-1} at an angle of 36° to the horizontal. The ball just passes over a wall of height h . The ball reaches the wall 0.17 s after it has been thrown.

- (a) Assuming air resistance to be negligible, calculate
 - (i) the horizontal distance of point P from the wall,

distance = m [2]

(ii) the height h of the wall.

For
Examiner's
Use

$$h = \dots\dots\dots \text{m} \quad [3]$$

- (b) A second ball is thrown from point P with the same velocity as the ball in (a). For this ball, air resistance is not negligible. This ball hits the wall and rebounds.

On Fig. 2.1, sketch the path of this ball between point P and the point where it first hits the ground. [2]

- 4 A student takes measurements to determine a value for the acceleration of free fall. Some of the apparatus used is illustrated in Fig. 4.1.

For Examiner's Use

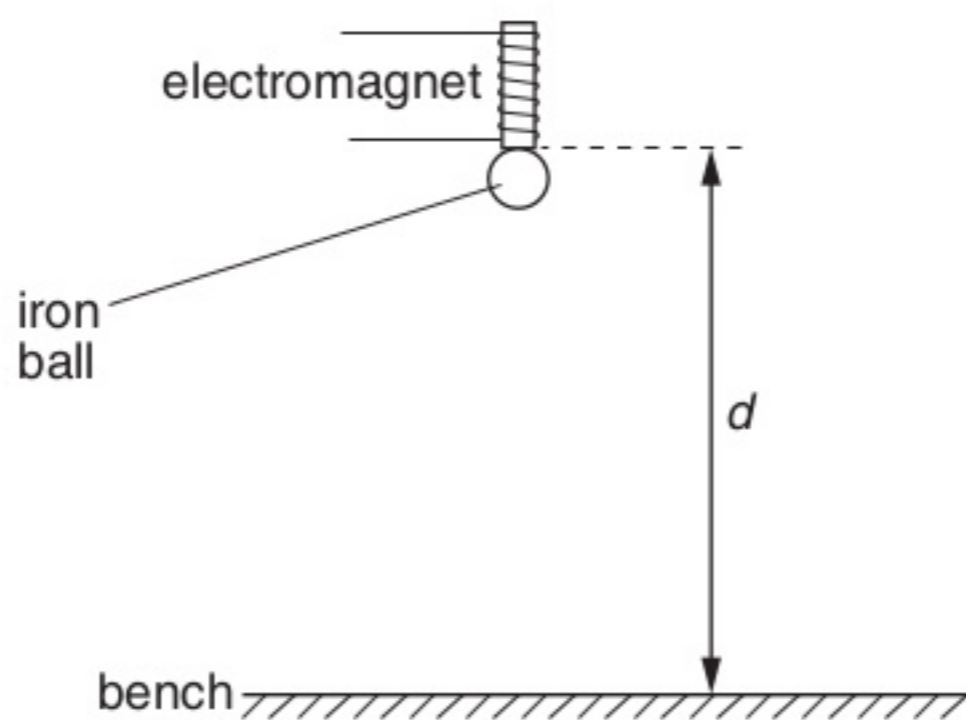

Fig. 4.1

The student measures the vertical distance d between the base of the electromagnet and the bench. The time t for an iron ball to fall from the electromagnet to the bench is also measured.

Corresponding values of t^2 and d are shown in Fig. 4.2.

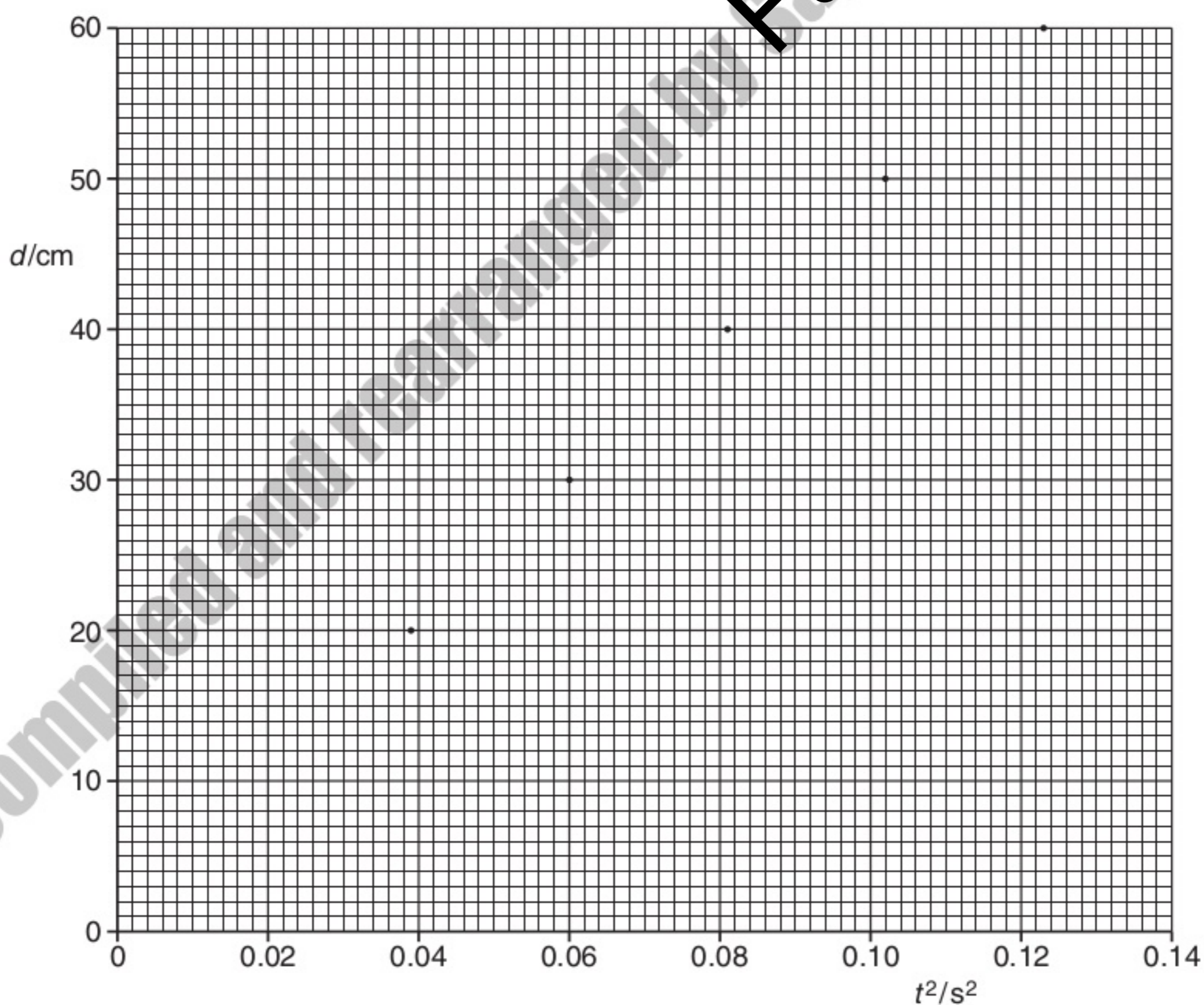

Fig. 4.2

(a) On Fig. 4.2, draw the line of best fit for the points. [1]

(b) State and explain why there is a non-zero intercept on the graph of Fig. 4.2.

.....
.....
..... [2]

(c) Determine the student's value for

(i) the diameter of the ball,

diameter = cm [1]

(ii) the acceleration of free fall.

acceleration = m s^{-2} [3]

For
Examiner's
Use

Compiled and rearranged by Fahad H. Ahmad
www.megalecture.com

1 (a) Distinguish between *scalar* quantities and *vector* quantities.

.....
.....
..... [2]

(b) In the following list, underline **all** the scalar quantities.

acceleration force kinetic energy mass power weight [1]

(c) A stone is thrown with a horizontal velocity of 20 ms^{-1} from the top of a cliff 15 m high. The path of the stone is shown in Fig. 1.1.

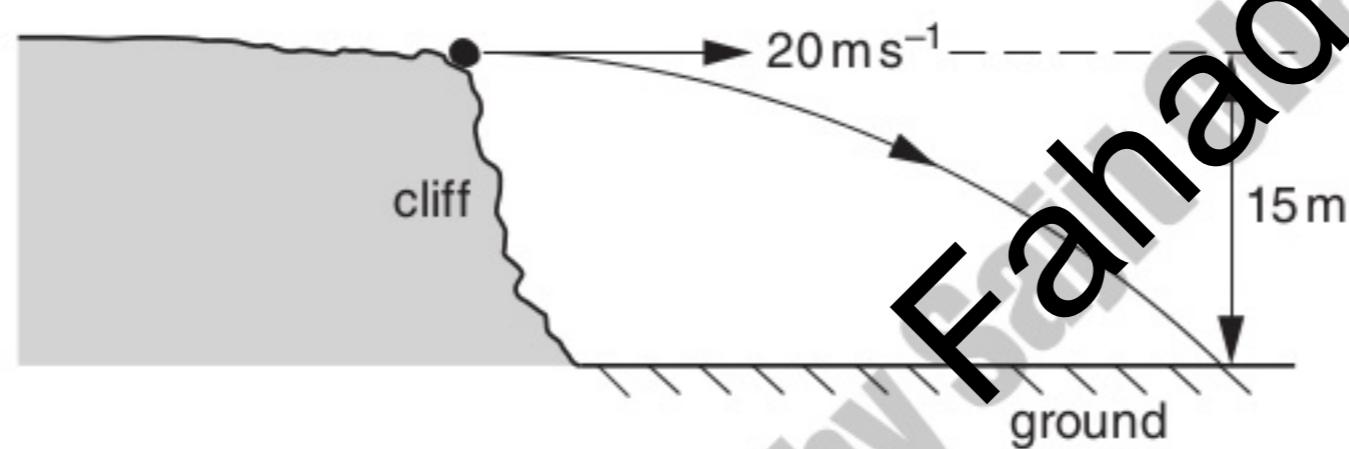

Fig. 1.1

Air resistance is negligible.

For this stone,

(i) calculate the time to fall 15 m ,

time = s [2]

(ii) calculate the magnitude of the resultant velocity after falling 15 m ,

resultant velocity = ms^{-1} [3]

(iii) describe the difference between the displacement of the stone and the distance that it travels.

For
Examiner's
Use

.....

.....

..... [2]

Compiled and rearranged by Fahad H. Ahmad

3 A helicopter has a cable hanging from it towards the sea below, as shown in Fig. 3.1.

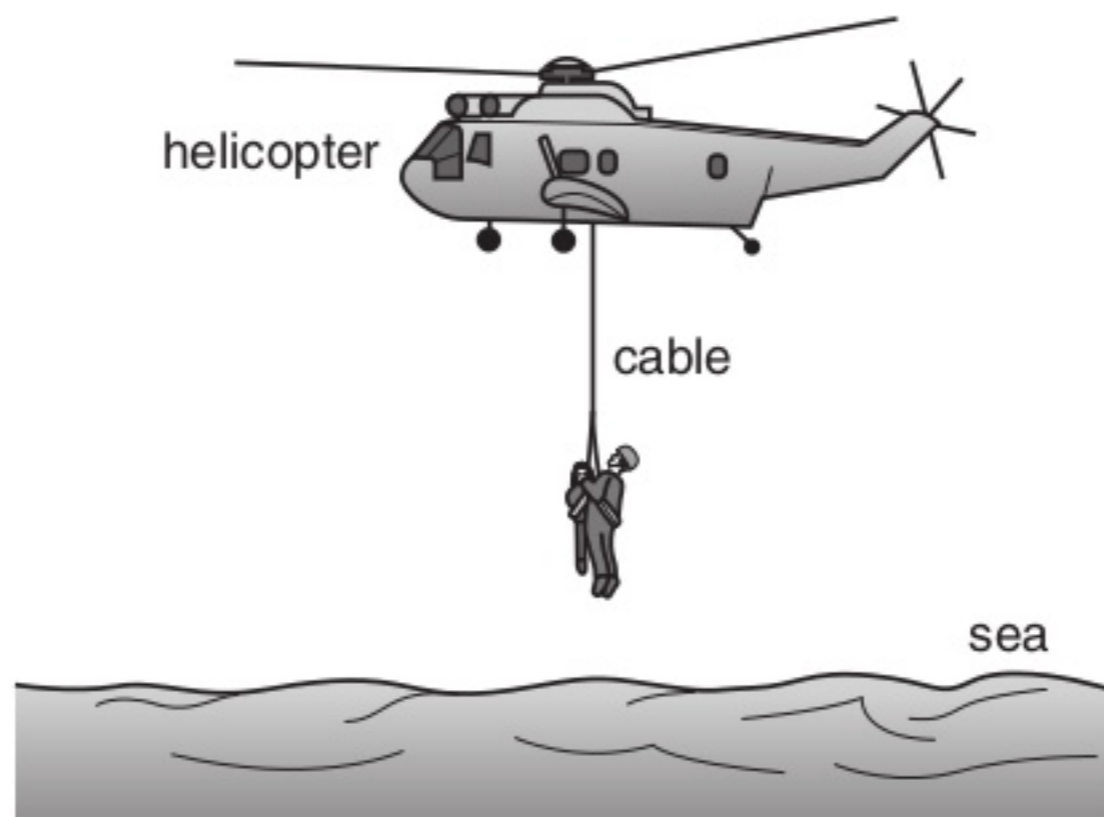

Fig. 3.1

A man of mass 80 kg rescues a child of mass 50.5 kg. The two are attached to the cable and are lifted from the sea to the helicopter. The lifting process consists of an initial uniform acceleration followed by a period of constant velocity and then completed by a final uniform deceleration.

(a) Calculate the combined weight of the man and child.

weight = N [1]

(b) Calculate the tension in the cable during

(i) the initial acceleration of 0.570 m s^{-2} ,

tension = N [2]

(ii) the period of constant velocity of 2.00 m s^{-1} .

tension = N [1]

For
Examiner's
Use

(c) During the final deceleration the tension in the cable is 1240N. Calculate this deceleration.

deceleration = ms^{-2} [2]

(d) (i) Calculate the time over which the man and child are

1. moving with uniform acceleration,

time = s [1]

2. moving with uniform deceleration.

time s [1]

(ii) The time over which the man and child are moving with constant velocity is 20s. On Fig. 3.2, sketch a graph to show the variation with time of the velocity of the man and child for the complete lifting process.

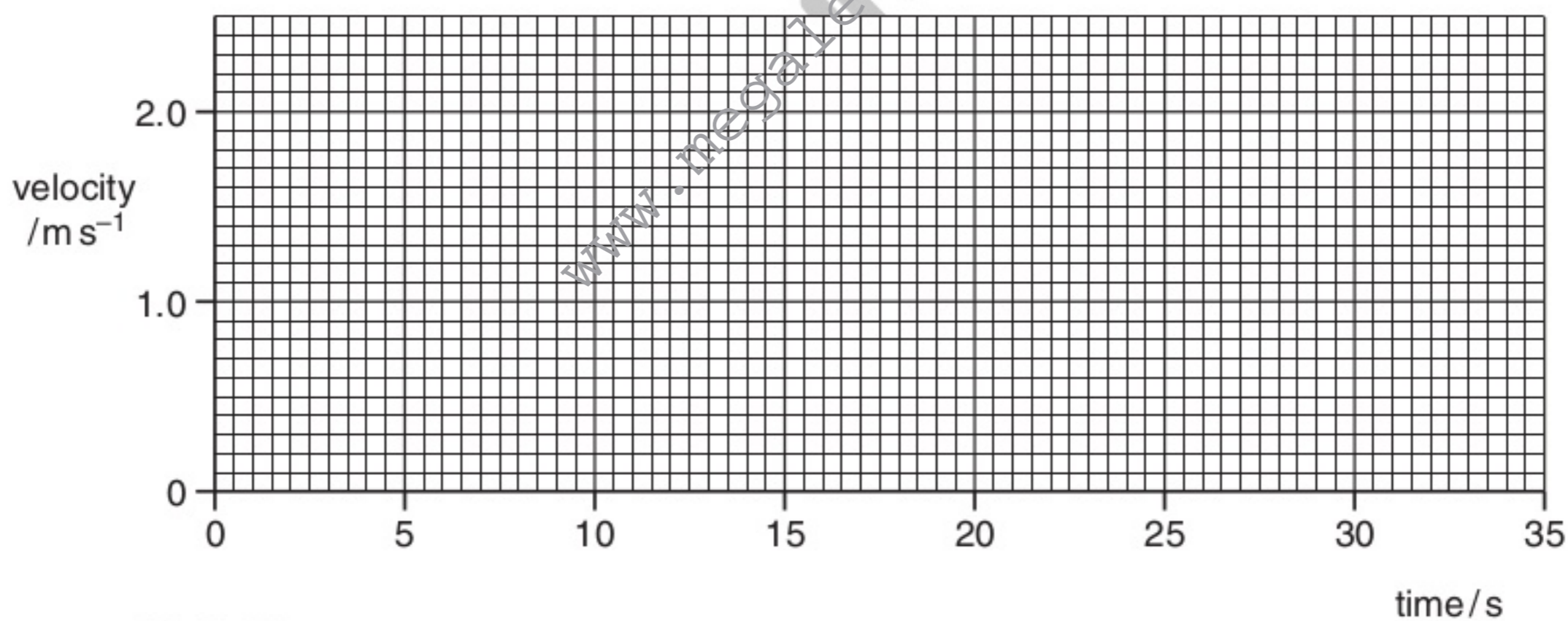

Fig. 3.2

[2]

3 A ball is thrown against a vertical wall. The path of the ball is shown in Fig. 3.1.

For
Examiner's
Use

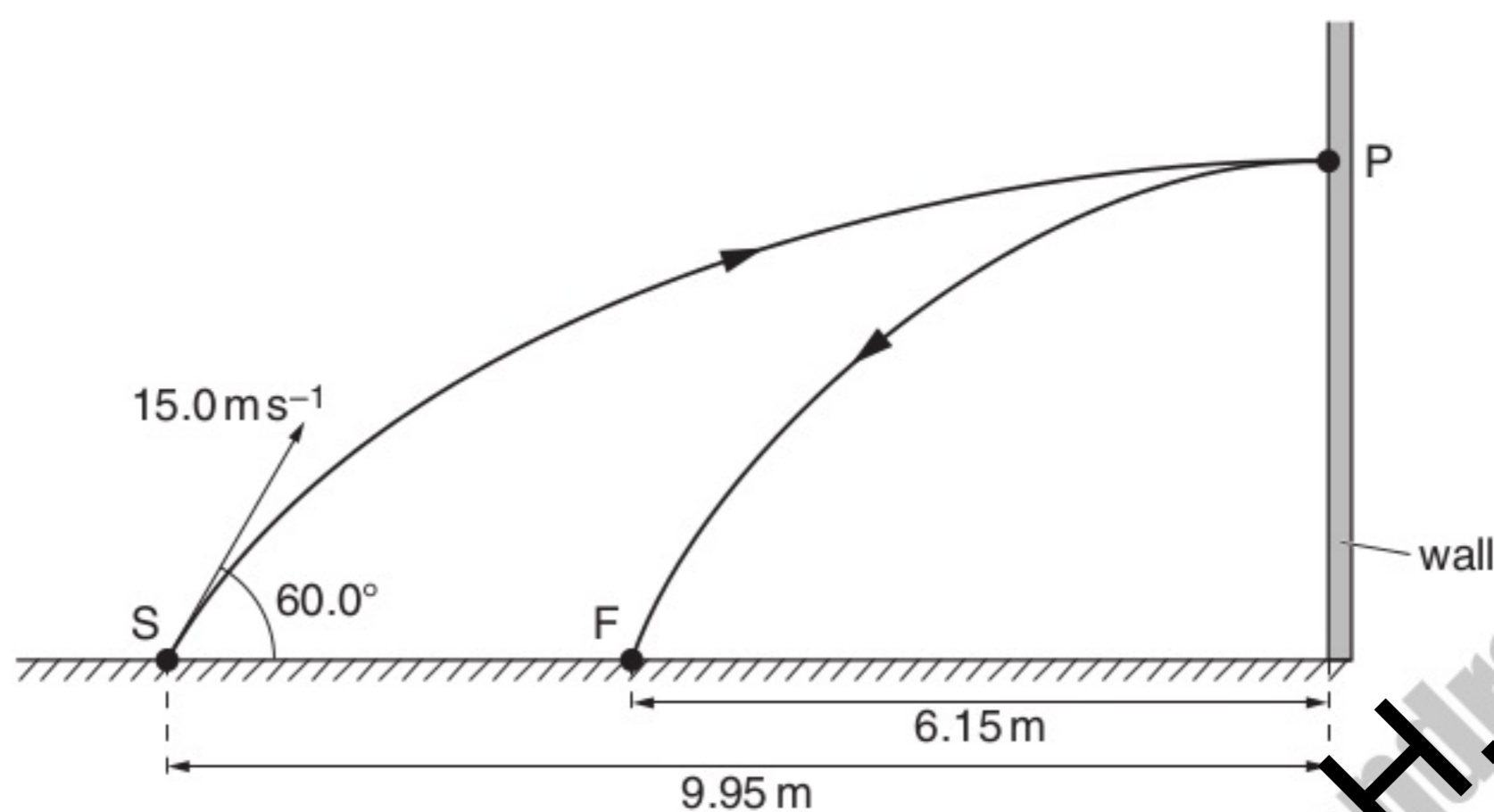

Fig. 3.1 (not to scale)

The ball is thrown from S with an initial velocity of 15.0 m s^{-1} at 60.0° to the horizontal. Assume that air resistance is negligible.

(a) For the ball at S, calculate

(i) its horizontal component of velocity,

horizontal component of velocity = m s^{-1} [1]

(ii) its vertical component of velocity.

vertical component of velocity = m s^{-1} [1]

(b) The horizontal distance from S to the wall is 9.95m. The ball hits the wall at P with a velocity that is at right angles to the wall. The ball rebounds to a point F that is 6.15m from the wall.

Using your answers in (a),

(i) calculate the vertical height gained by the ball when it travels from S to P,

height = m [1]

(ii) show that the time taken for the ball to travel from S to P is 1.33 s,

[1]

(iii) show that the velocity of the ball immediately after rebounding from the wall is about 4.6 ms^{-1} .

[1]

(c) The mass of the ball is $60 \times 10^{-3} \text{ kg}$.

(i) Calculate the change in momentum of the ball as it rebounds from the wall.

change in momentum = N s [2]

(ii) State and explain whether the collision is elastic or inelastic.

.....
.....
..... [1]

Compiled and read by Fahad H. Ahmad

1 The variation with time t of the displacement s for a car is shown in Fig. 1.1.

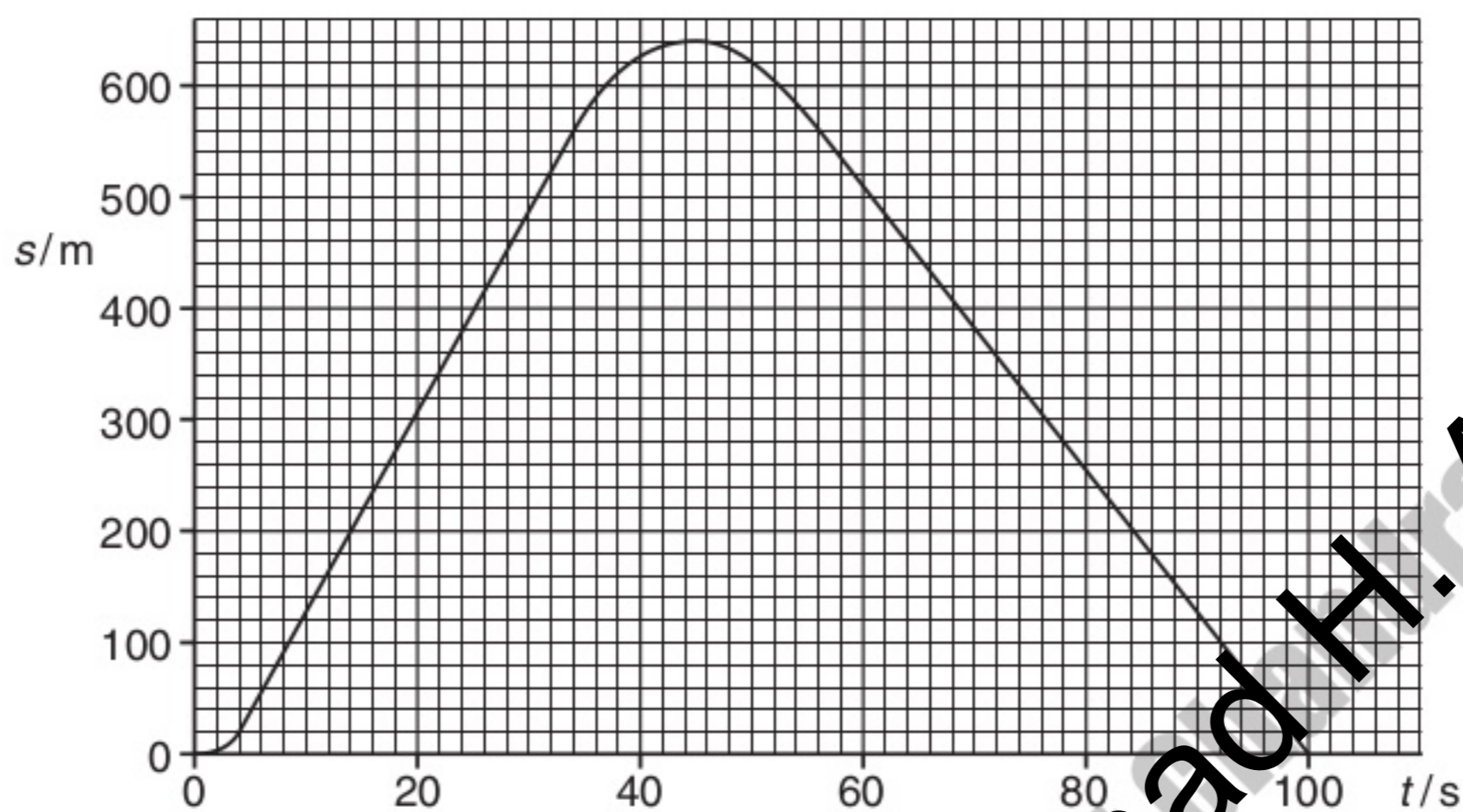

Fig. 1.1

(a) Determine the magnitude of the average velocity between the times 5.0 s and 35.0 s.

average velocity = ms^{-1} [2]

(b) On Fig. 1.2, sketch the variation with time t of the velocity v for the car.

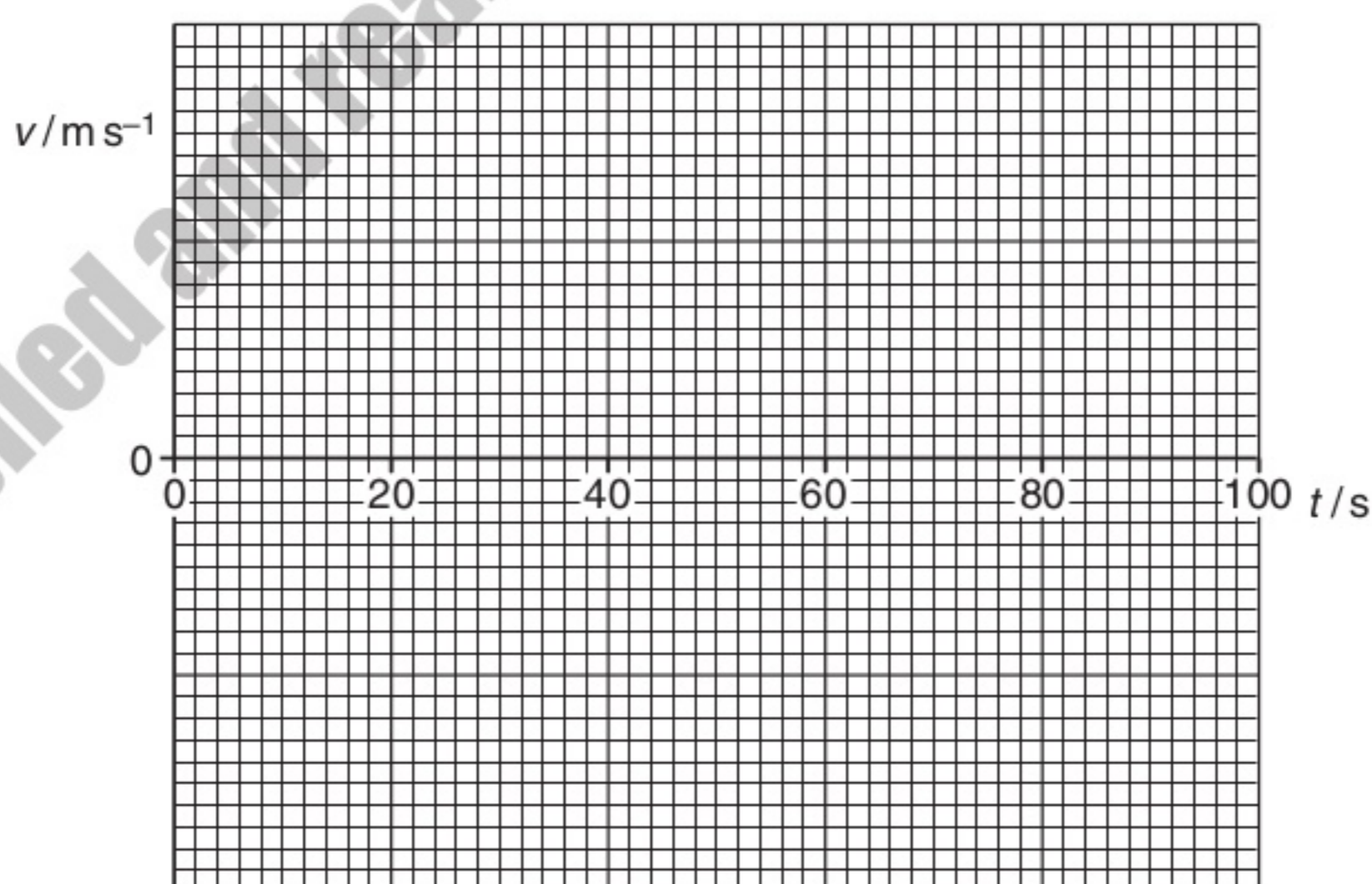

Fig. 1.2

[4]

2 The variation with time t of velocity v of a car is shown in Fig. 2.1.

For
Examiner's
Use

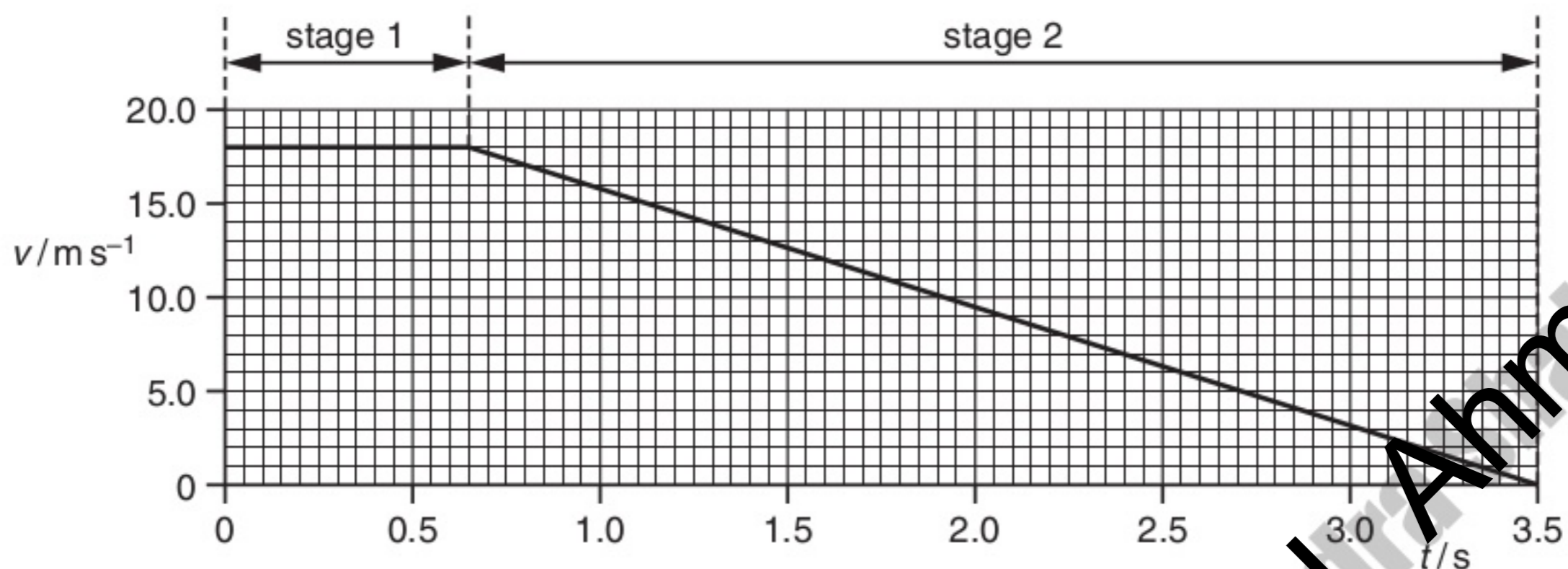

Fig. 2.1

At time $t = 0$, the driver sees an obstacle in the road. A short time later, the driver applies the brakes. The car travels in two stages, as shown in Fig. 2.1.

(a) Use Fig. 2.1 to describe the velocity of the car in

1. stage 1,

.....
 [1]

2. stage 2.

.....
 [1]

(b) (i) Calculate the distance travelled by the car from $t = 0$ to $t = 3.5$ s.

total distance = m [2]

- (ii) The car has a total mass of 1250 kg. Determine the total resistive force acting on the car in stage 2.

For Examiner's Use

force = N [3]

- (c) For safety reasons drivers are asked to travel at lower speeds. For each stage describe and explain the effect on the distance travelled for the same car and driver travelling at half the initial speed shown in Fig. 2.1.

- (i) stage 1:

.....

 [1]

- (ii) stage 2:

.....

 [2]

Compiled and rearranged by Fahad H. Ahmad

2 A ball is thrown vertically down towards the ground with an initial velocity of 4.23 m s^{-1} . The ball falls for a time of 1.51 s before hitting the ground. Air resistance is negligible.

For Examiner's Use

(a) (i) Show that the downwards velocity of the ball when it hits the ground is 19.0 m s^{-1} .

[2]

(ii) Calculate, to three significant figures, the distance the ball falls to the ground.

distance = m [2]

(b) The ball makes contact with the ground for 12.5 ms and rebounds with an upwards velocity of 18.6 m s^{-1} . The mass of the ball is 46.5 g.

(i) Calculate the average force acting on the ball on impact with the ground.

magnitude of force = N

direction of force

[4]

(ii) Use conservation of energy to determine the maximum height the ball reaches after it hits the ground.

height = m [2]

(c) State and explain whether the collision the ball makes with the ground is elastic or inelastic.

.....
.....
..... [1]

- 2 (a) A ball is thrown vertically down towards the ground and rebounds as illustrated in Fig. 2.1.

For
Examiner's
Use

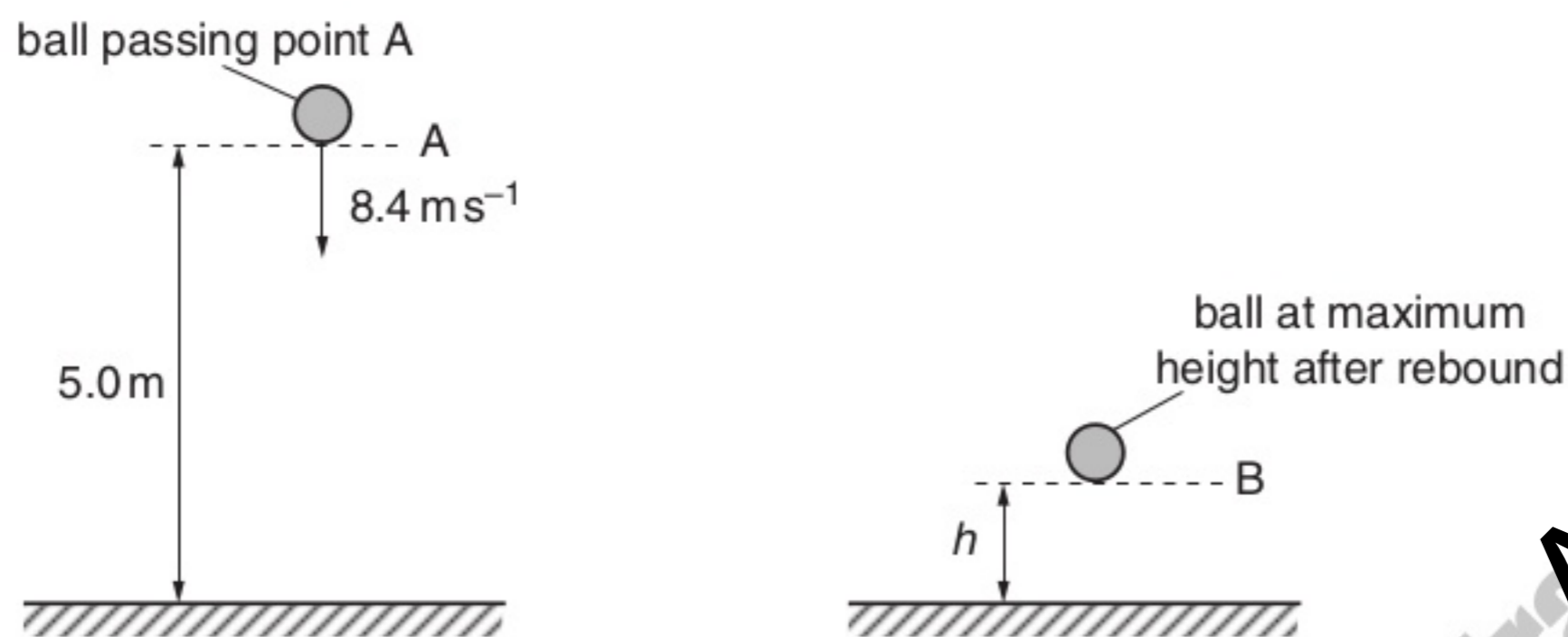

Fig. 2.1

As the ball passes A, it has a speed of 8.4 ms^{-1} . The height of A is 5.0m above the ground. The ball hits the ground and rebounds to B. Assume that air resistance is negligible.

- (i) Calculate the speed of the ball as it hits the ground.

speed = ms^{-1} [2]

- (ii) Show that the time taken for the ball to reach the ground is 0.47 s.

[1]

- (b) The ball rebounds vertically with a speed of 4.2 ms^{-1} as it leaves the ground. The time the ball is in contact with the ground is 20 ms. The ball rebounds to a maximum height h .

The ball passes A at time $t = 0$. On Fig. 2.2, plot a graph to show the variation with time t of the velocity v of the ball. Continue the graph until the ball has rebounded from the ground and reaches B.

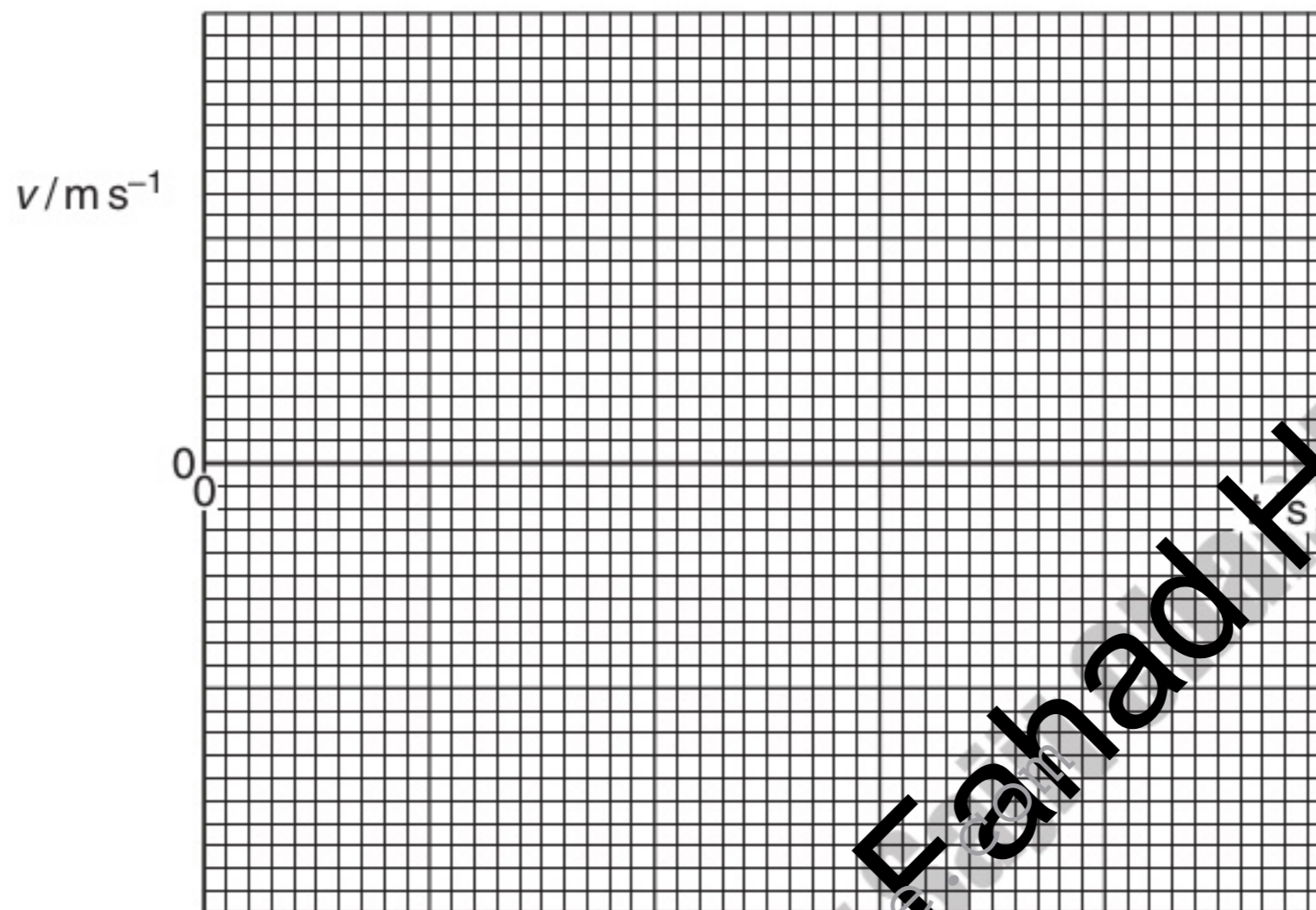

Fig. 2.2

[3]

- (c) The ball has a mass of 0.050 kg. It moves from A and reaches B after rebounding.

- (i) For this motion, calculate the change in

1. kinetic energy,

change in kinetic energy = J [2]

2. gravitational potential energy.

change in potential energy = J [3]

(ii) State and explain the total change in energy of the ball for this motion.

For
Examiner's
Use

.....

.....

.....

..... [2]

Compiled and rearranged by Fahad H. Ahmad

2 Two planks of wood AB and BC are inclined at an angle of 15° to the horizontal. The two wooden planks are joined at point B, as shown in Fig. 2.1.

For
Examiner's
Use

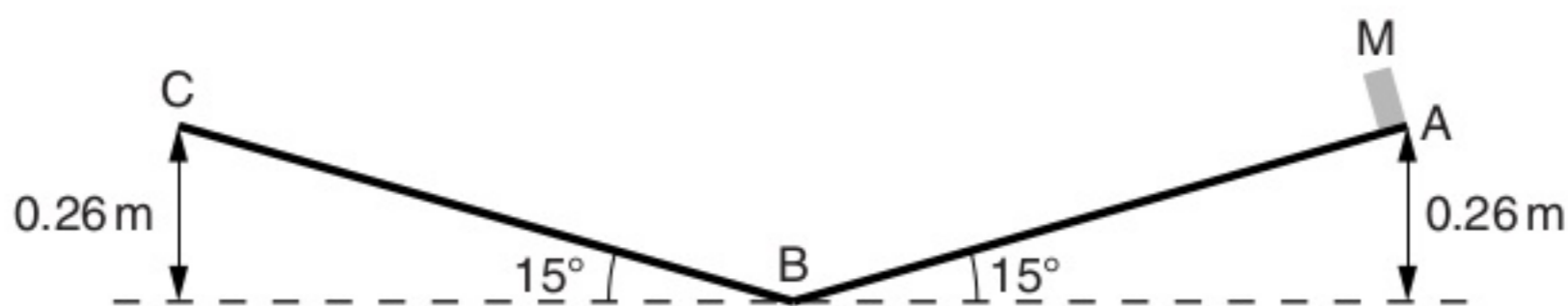

Fig. 2.1

A small block of metal M is released from rest at point A. It slides down the slope to B and up the opposite side to C. Points A and C are 0.26 m above B. Assume frictional forces are negligible.

(a) (i) Describe and explain the acceleration of M as it travels from A to B and from B to C.

.....

 [3]

(ii) Calculate the time taken for M to travel from A to B.

time = s [3]

(iii) Calculate the speed of M at B.

speed = ms^{-1} [2]

(b) The plank BC is adjusted so that the angle it makes with the horizontal is 30° . M is released from rest at point A and slides down the slope to B. It then slides a distance along the plank from B towards C.

Use the law of conservation of energy to calculate this distance. Explain your working.

distance = m [2]

Answer **all** the questions in the spaces provided.

For
Examiner's
Use

1 (a) (i) Define *acceleration*.

.....
..... [1]

(ii) State Newton's first law of motion.

.....
..... [1]

(b) The variation with time t of vertical speed v of a parachutist falling from an aircraft is shown in Fig. 1.1.

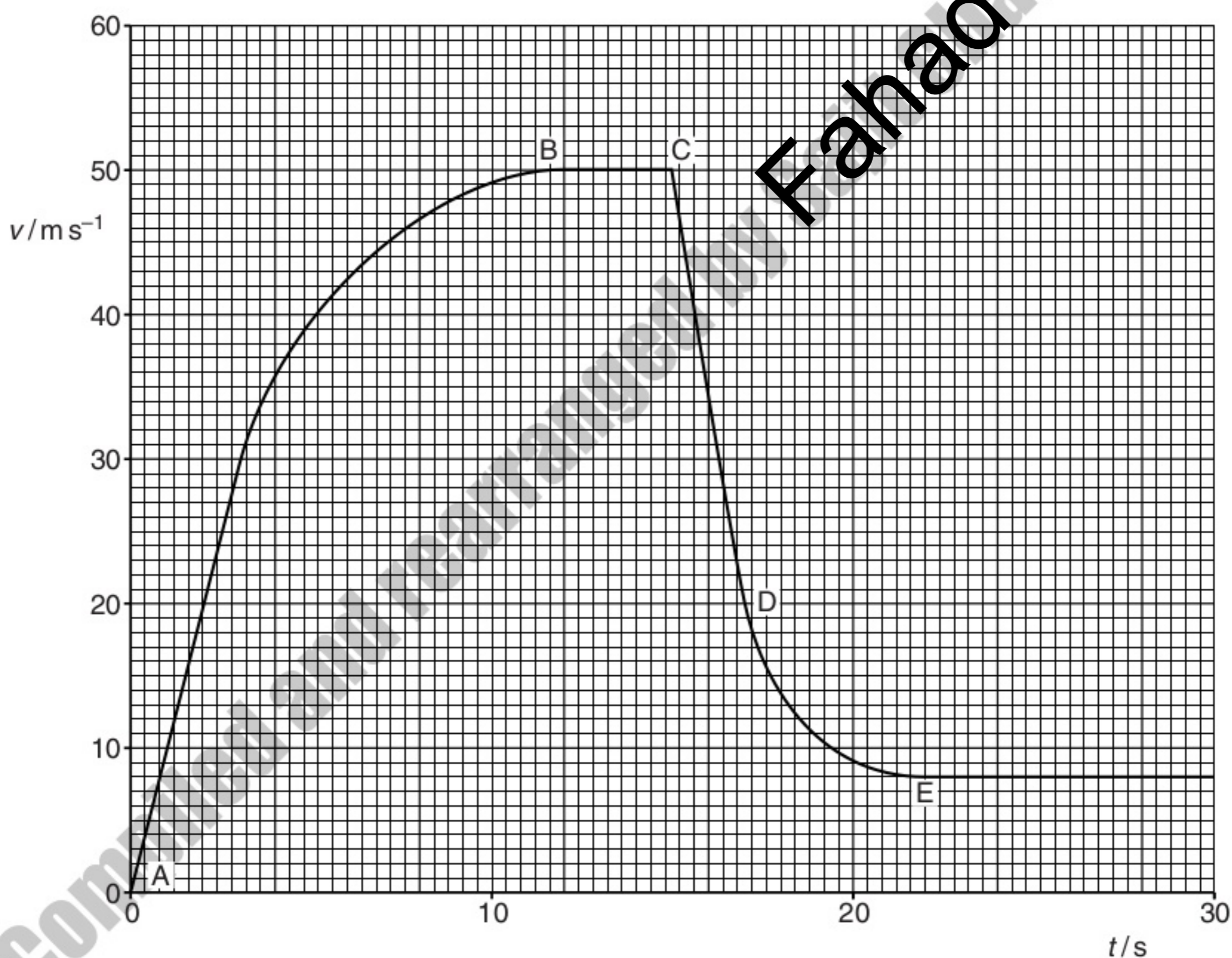

Fig. 1.1

(i) Calculate the distance travelled by the parachutist in the first 3.0 s of the motion.

For
Examiner's
Use

distance = m [2]

(ii) Explain the variation of the resultant force acting on the parachutist from $t = 0$ (point A) to $t = 15$ s (point C).

.....
.....
.....
.....
..... [3]

(iii) Describe the changes to the frictional force on the parachutist

1. at $t = 15$ s (point C),

.....
.....
..... [1]

2. between $t = 15$ s (point C) and $t = 22$ s (point E).

.....
.....
..... [1]

Compiled and reamanged by Fozhad H. Ahmad

(iv) The mass of the parachutist is 95 kg.

Calculate, for the parachutist between $t = 15$ s (point C) and $t = 17$ s (point D),

1. the average acceleration,

acceleration = m/s² [2]

2. the average frictional force.

frictional force = N [3]

For
Examiner's
Use

Compiled and rearranged by Fahad H. Ahmad