

- 9 Two similar spheres, each of mass m and travelling with speed v , are moving towards each other.

9702/1/M/J/02



The spheres have a head-on elastic collision.

Which statement is correct?

- A The spheres stick together on impact.
 - B The total kinetic energy after impact is mv^2 .
 - C The total kinetic energy before impact is zero.
 - D The total momentum before impact is $2mv$.
- 11 A body, initially at rest, explodes into two masses M_1 and M_2 that move apart with speeds v_1 and v_2 respectively.

9702/1/M/J/02

What is the ratio $\frac{v_1}{v_2}$?

- A $\frac{M_1}{M_2}$
- B $\frac{M_2}{M_1}$
- C $\left(\frac{M_1}{M_2}\right)^{\frac{1}{2}}$
- D $\left(\frac{M_2}{M_1}\right)^{\frac{1}{2}}$

- 11 Two spheres A and B approach each other along the same straight line with speeds u_A and u_B . The spheres collide and move off with speeds v_A and v_B , both in the same direction as the initial direction of sphere A, as shown below.

9702/1/O/N/02

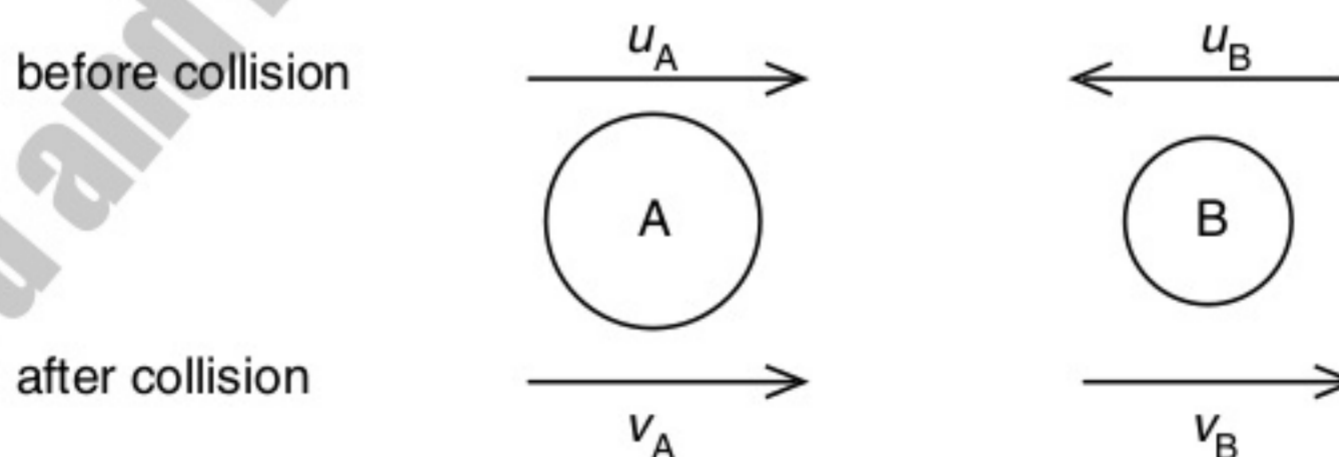

Which equation applies to an elastic collision?

- A $u_A + u_B = v_B - v_A$
- B $u_A - u_B = v_B - v_A$
- C $u_A - u_B = v_B + v_A$
- D $u_A + u_B = v_B + v_A$

- 12 Two equal masses travel towards each other on a frictionless air track at speeds of 60 cm s^{-1} and 30 cm s^{-1} . They stick together on impact. 9702/1/O/N/02



What is the speed of the masses after impact?

- A 15 cm s^{-1} B 20 cm s^{-1} C 30 cm s^{-1} D 45 cm s^{-1}
- 10 Two blocks X and Y, of masses m and $3m$ respectively, are accelerated along a smooth horizontal surface by a force F applied to block X as shown. 9702/01/M/J/03

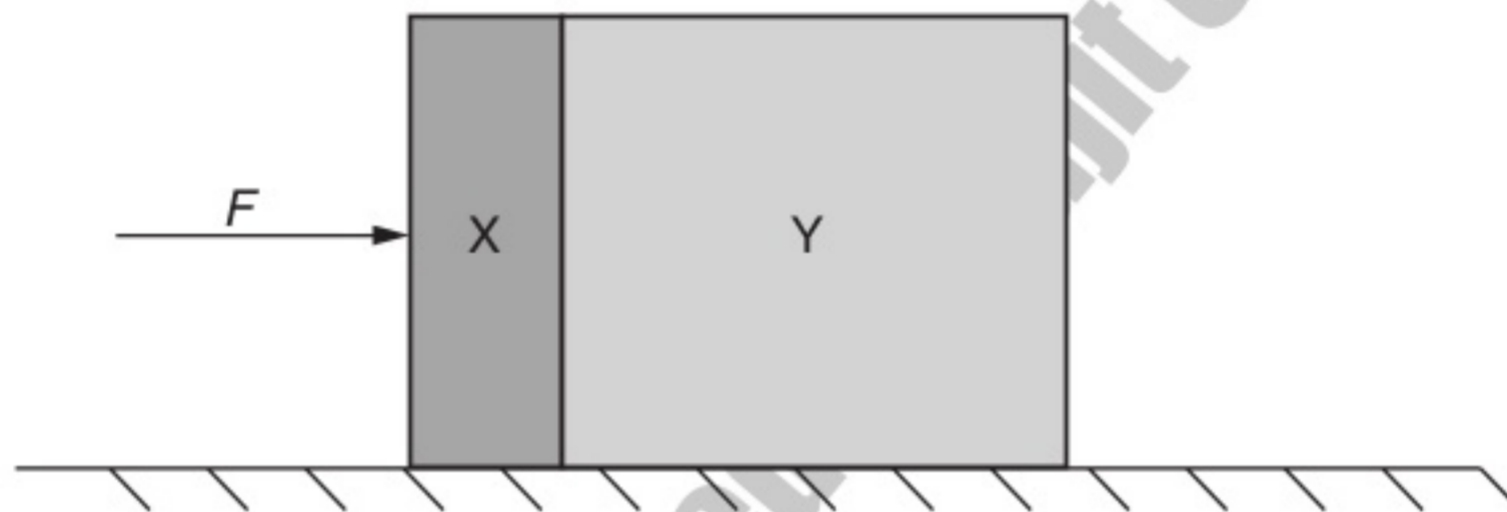

What is the magnitude of the force exerted by block X on block Y during this acceleration?

- A $\frac{F}{4}$ B $\frac{F}{3}$ C $\frac{F}{2}$ D $\frac{3F}{4}$
- 12 A ball of mass 2 kg travelling at 8 m s^{-1} strikes a ball of mass 4 kg travelling at 2 m s^{-1} . Both balls are moving along the same straight line as shown. 9702/01/M/J/03



After collision, both balls move at the same velocity v .

What is the magnitude of the velocity v ?

- A 4 m s^{-1} B 5 m s^{-1} C 6 m s^{-1} D 8 m s^{-1}

10 A mass accelerates uniformly when the resultant force acting on it

9702/01/O/N/03

- A is zero.
- B is constant but not zero.
- C increases uniformly with respect to time.
- D is proportional to the displacement from a fixed point.

11 A molecule of mass m travelling horizontally with velocity u hits a vertical wall at right angles to the wall. It then rebounds horizontally with the same speed.

9702/01/O/N/03

What is its change in momentum?

- A zero B mu C $-mu$ D $-2mu$

12 Two balls X and Y approach each other along the same straight line and collide elastically.

Their speeds are u_X and u_Y respectively. After the collision they move apart with speeds v_X and v_Y respectively. Their directions are shown on the diagram.

9702/01/O/N/03

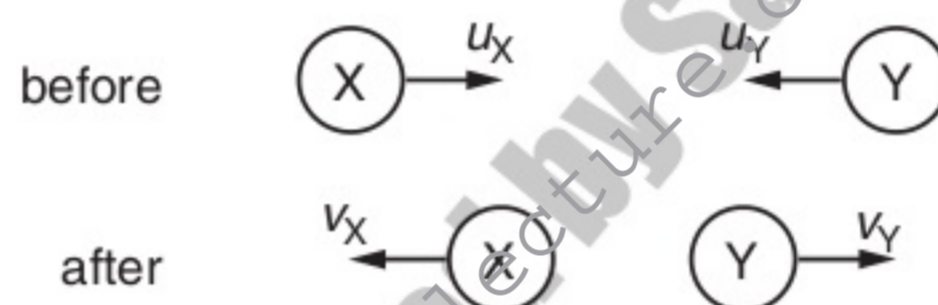

Which of the following equations is correct?

- A $u_X + u_Y = v_X + v_Y$
- B $u_X + u_Y = v_X - v_Y$
- C $u_X - u_Y = v_X + v_Y$
- D $u_X - u_Y = v_X - v_Y$

11 Two equal masses travel towards each other on a frictionless air track at speeds of 60 cm s^{-1} and 40 cm s^{-1} . They stick together on impact.

9702/01/M/J/05



What is the speed of the masses after impact?

- A 10 cm s^{-1} B 20 cm s^{-1} C 40 cm s^{-1} D 50 cm s^{-1}

- 10 A ball falls vertically and bounces on the ground.

9702/01/M/J/04

The following statements are about the forces acting while the ball is in contact with the ground.

Which statement is correct?

- A** The force that the ball exerts on the ground is always equal to the weight of the ball.
- B** The force that the ball exerts on the ground is always equal in magnitude and opposite in direction to the force the ground exerts on the ball.
- C** The force that the ball exerts on the ground is always less than the weight of the ball.
- D** The weight of the ball is always equal in magnitude and opposite in direction to the force that the ground exerts on the ball.
- 11 The diagram shows a situation just before a head-on collision. A lorry of mass 20 000 kg is travelling at 20.0 ms^{-1} towards a car of mass 900 kg travelling at 30.0 ms^{-1} towards the lorry.

9702/01/M/J/04

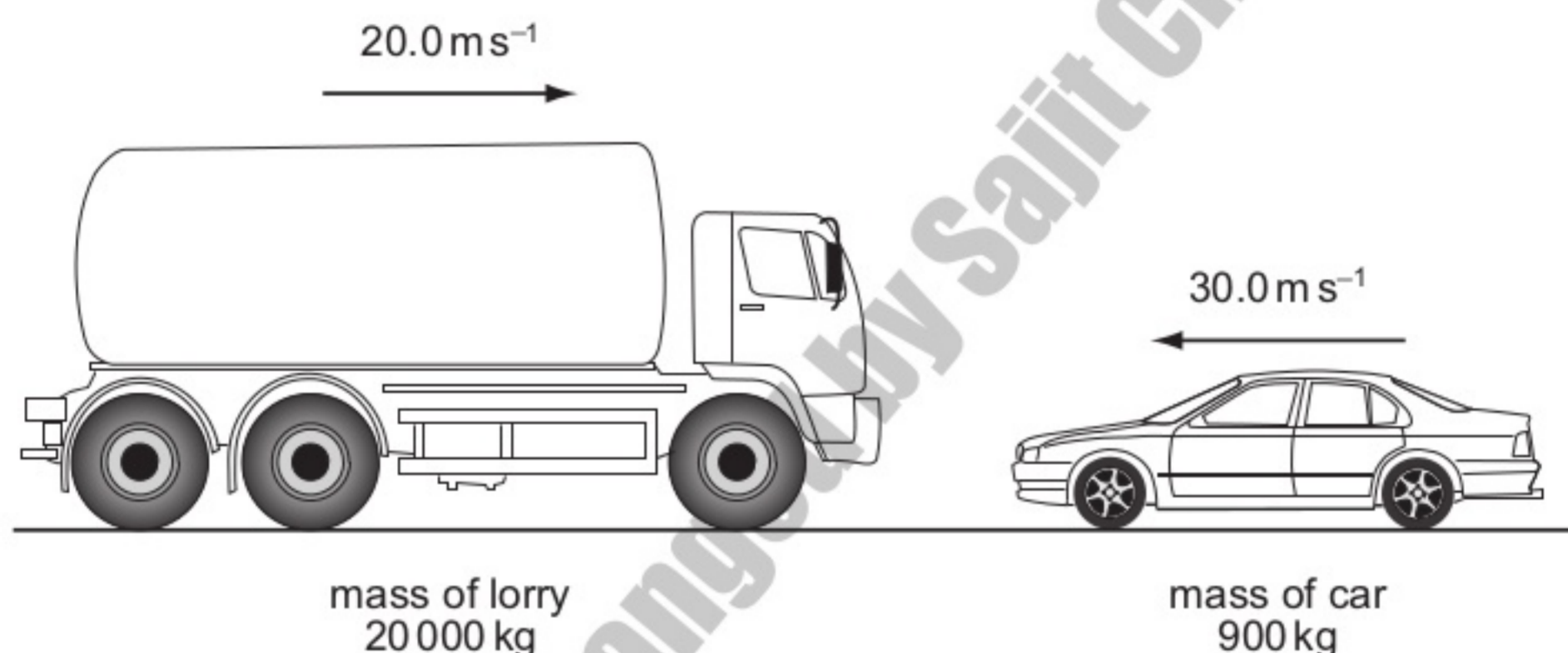

What is the magnitude of the total momentum?

- A** 373 kNs **B** 427 kNs **C** 3600 kNs **D** 4410 kNs
- 9 Which of the following is a statement of the principle of conservation of momentum?

9702/01/O/N/03

- A** Momentum is the product of mass and velocity.
- B** In an elastic collision, momentum is constant.
- C** The momentum of an isolated system is constant.
- D** The force acting on a body is proportional to its rate of change of momentum.

- 12 Two railway trucks of masses m and $3m$ move towards each other in opposite directions with speeds $2v$ and v respectively. These trucks collide and stick together.

9702/01/M/J/06

What is the speed of the trucks after the collision?

- A** $\frac{v}{4}$ **B** $\frac{v}{2}$ **C** v **D** $\frac{5v}{4}$

- 11 A particle of mass m strikes a vertical rigid wall perpendicularly from the left with velocity v .

9702/01/O/N/04

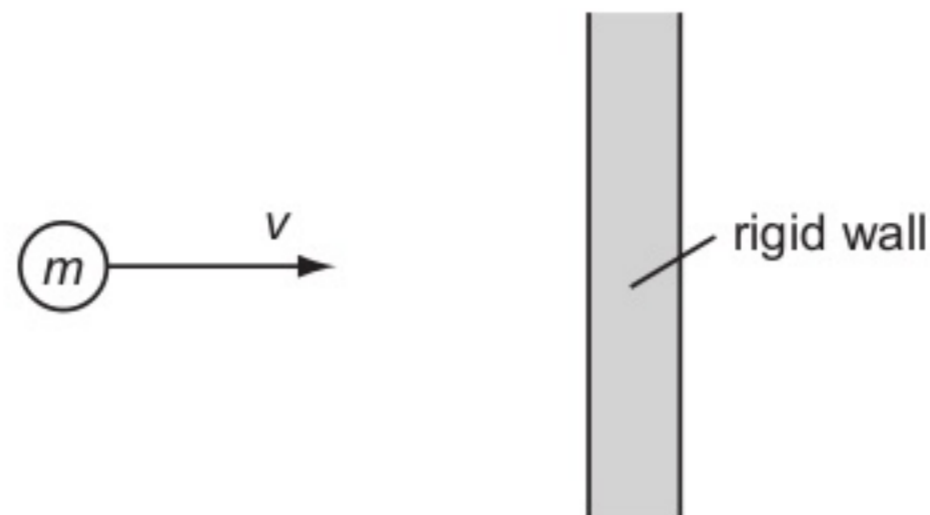

If the collision is perfectly elastic, the total change in momentum of the particle that occurs as a result of the collision is

- A $2mv$ to the right.
 B $2mv$ to the left.
 C mv to the right.
 D mv to the left.
- 10 Which is **not** one of Newton's laws of motion? 9702/01/M/J/05
- A The total momentum of a system of interacting bodies remains constant, providing no external force acts.
 B The rate of change of momentum of a body is directly proportional to the external force acting on the body and takes place in the direction of the force.
 C If body A exerts a force on body B, then body B exerts an equal and oppositely-directed force on body A.
 D A body continues in a state of rest or of uniform motion in a straight line unless acted upon by some external force.
- 10 A constant mass undergoes uniform acceleration. 9702/01/O/N/04
- Which of the following is a correct statement about the resultant force acting on the mass?
- A It increases uniformly with respect to time.
 B It is constant but not zero.
 C It is proportional to the displacement from a fixed point.
 D It is proportional to the velocity.
- 12 What is the centre of gravity of an object? 9702/01/M/J/05
- A the geometrical centre of the object
 B the point about which the total torque is zero
 C the point at which the weight of the object may be considered to act
 D the point through which gravity acts

- 9 Which is a statement of the principle of conservation of momentum? 9702/01/O/N/05
- A** A force is equal to the rate of change of momentum of the body upon which it acts.
- B** In a perfectly elastic collision, the relative momentum of the bodies before impact is equal to their relative momentum after impact.
- C** The momentum of a body is the product of the mass of the body and its velocity.
- D** The total momentum of a system of interacting bodies remains constant, providing no external force acts.

- 10 The gravitational field strength on the surface of planet P is one tenth of that on the surface of planet Q. 9702/01/O/N/05

On the surface of P, a body has its mass measured to be 1.0 kg and its weight measured to be 1.0 N.

What results are obtained for measurements of the mass and weight of the same body on the surface of planet Q?

	mass on Q	weight on Q
A	1.0 kg	0.1 N
B	1.0 kg	10 N
C	10 kg	10 N
D	10 kg	100 N

- 10 A cyclist is riding at a steady speed on a level road. 9702/01/M/J/06

According to Newton's third law of motion, what is equal and opposite to the backward push of the back wheel on the road?

- A** the force exerted by the cyclist on the pedals
- B** the forward push of the road on the back wheel
- C** the tension in the cycle chain
- D** the total air resistance and friction force
- 11 In perfectly elastic collisions between two atoms, it is always true to say that 9702/01/M/J/06
- A** the initial speed of one atom will be the same as the final speed of the other atom.
- B** the relative speed of approach between the two atoms equals their relative speed of separation.
- C** the total momentum must be conserved, but a small amount of the total kinetic energy may be lost in the collision.
- D** whatever their initial states of motion, neither atom can be stationary after the collision.

10 A force F is applied to a freely moving object. At one instant of time, the object has velocity v and acceleration a .

9702/01/O/N/06

Which quantities **must** be in the same direction?

- A a and v only
- B a and F only
- C v and F only
- D v , F and a

11 The diagram shows two identical spheres X and Y.

9702/01/O/N/06

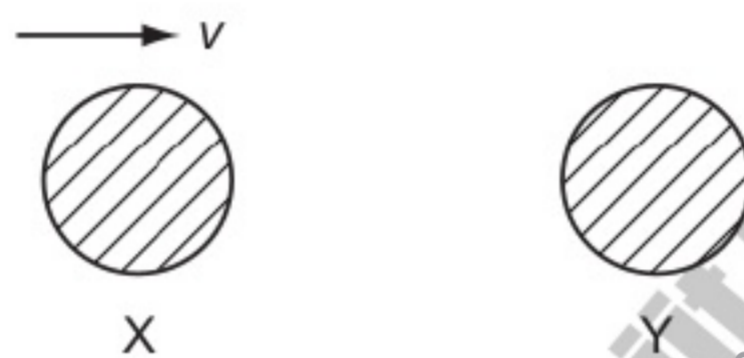

Initially X moves with speed v directly towards Y. Y is stationary. The spheres collide elastically.

What happens?

	X	Y
A	moves with speed $\frac{1}{2}v$ to the right	moves with speed $\frac{1}{2}v$ to the right
B	moves with speed v to the left	remains stationary
C	moves with speed $\frac{1}{2}v$ to the left	moves with speed $\frac{1}{2}v$ to the right
D	stops	moves with speed v to the right

12 The diagram shows a cannon ball fired from a cannon.

9702/01/O/N/06

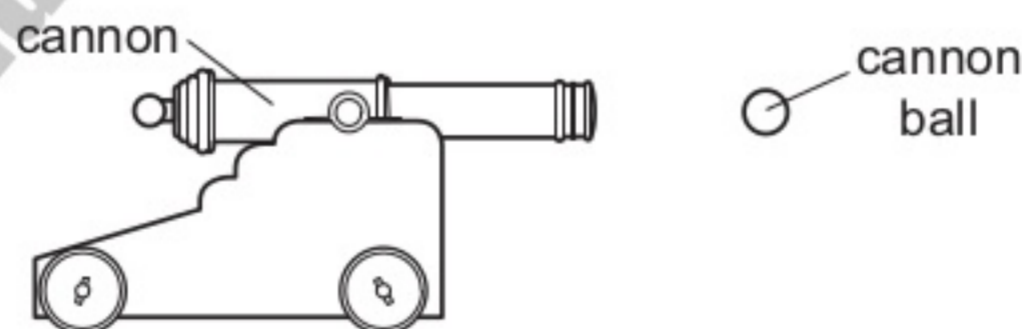

The mass of the cannon is 1000 kg and the mass of the cannon ball is 10 kg.

The recoil velocity of the cannon is 5 ms^{-1} horizontally.

What is the horizontal velocity of the cannon ball?

- A 200 ms^{-1}
- B 500 ms^{-1}
- C 2000 ms^{-1}
- D 5000 ms^{-1}

- 7 An object has an initial velocity u . It is subjected to a constant force F for t seconds, causing a constant acceleration a . The force is **not** in the same direction as the initial velocity. 9702/01/M/J/07

A vector diagram is drawn to find the final velocity v .

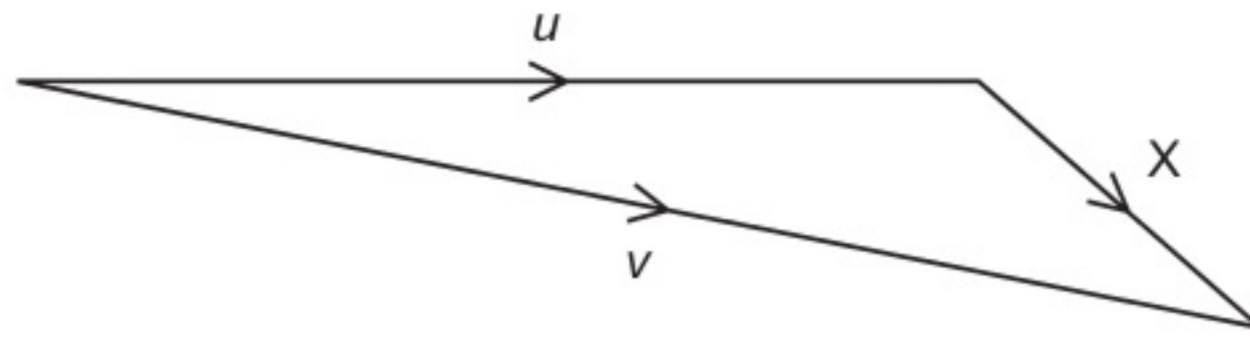

What is the length of side X of the vector diagram?

- A F B Ft C at D $u + at$
- 9 What is meant by the weight of an object? 9702/01/M/J/07
- A the gravitational field acting on the object
 B the gravitational force acting on the object
 C the mass of the object multiplied by gravity
 D the object's mass multiplied by its acceleration
- 10 The graph shows the variation with time of the momentum of a ball as it is kicked in a straight line. 9702/01/M/J/07

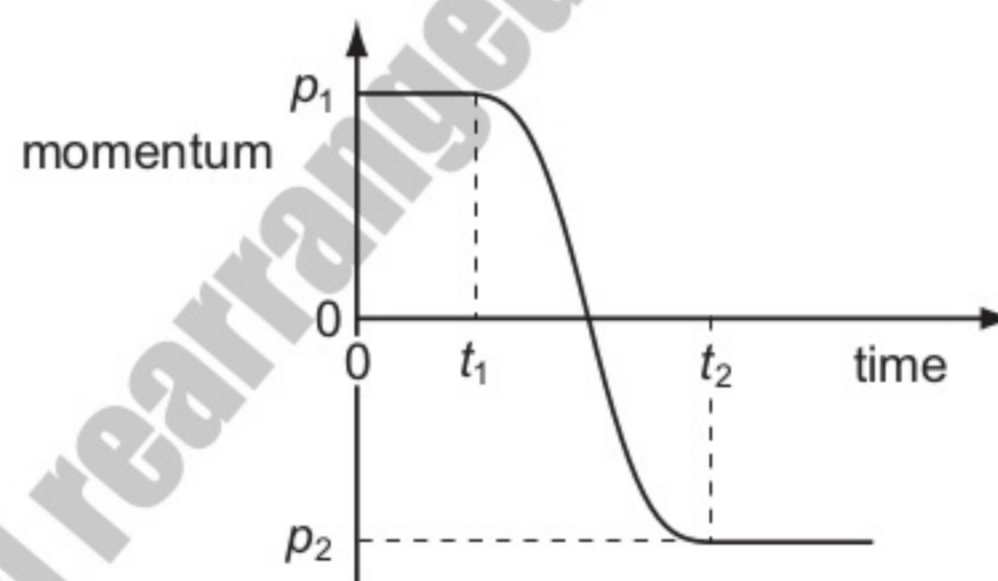

Initially, the momentum is p_1 at time t_1 . At time t_2 the momentum is p_2 .

What is the magnitude of the average force acting on the ball between times t_1 and t_2 ?

- A $\frac{p_1 - p_2}{t_2}$ B $\frac{p_1 - p_2}{t_2 - t_1}$ C $\frac{p_1 + p_2}{t_2}$ D $\frac{p_1 + p_2}{t_2 - t_1}$
- 7 Which statement about Newton's laws of motion is correct? 9702/01/M/J/09
- A The first law follows from the second law.
 B The third law follows from the second law.
 C Conservation of energy is a consequence of the third law.
 D Conservation of linear momentum is a consequence of the first law.

- 11 A lorry of mass $20\,000\text{ kg}$ is travelling at 20.0 m s^{-1} . A car of mass 900 kg is travelling at 30.0 m s^{-1} towards the lorry. 9702/01/M/J/07

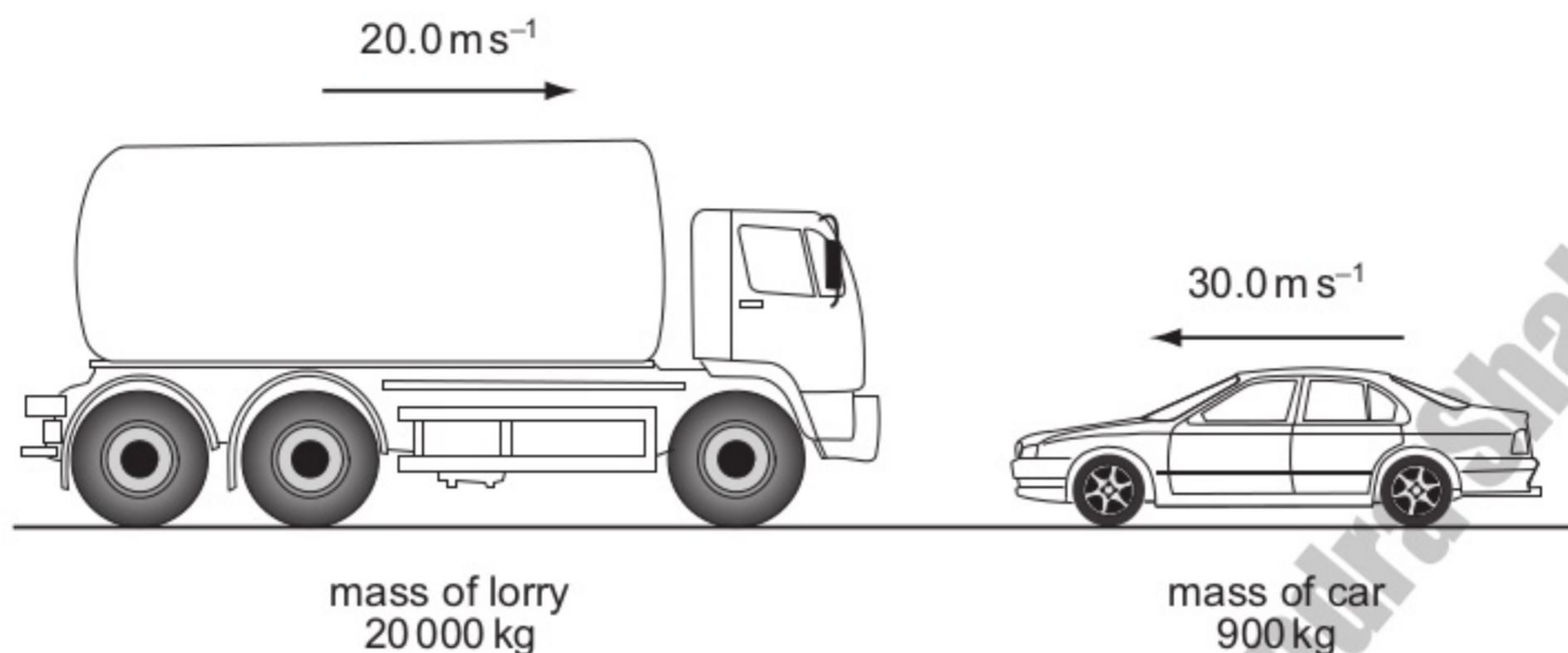

What is the magnitude of the total momentum?

- A 209 kNs B 373 kNs C 427 kNs D 1045 kNs
- 12 The diagram shows the masses and velocities of two trolleys about to collide. 9702/01/M/J/07



After the impact they move off together

What is the total kinetic energy of the trolleys after the collision?

- A 1.3 J B 12 J C 18 J D 19 J
- 9 Which is a statement of the principle of conservation of momentum? 9702/01/M/J/08

- A Momentum is the product of mass and velocity.
 B Momentum is conserved only in elastic collisions.
 C Momentum is conserved by all bodies in a collision.
 D Momentum is conserved providing no external forces act.

- 7 Which statement about a ball that strikes a tennis racket and rebounds is **always** correct? 9702/12/O/N/09

- A Total kinetic energy of the ball is conserved.
 B Total kinetic energy of the system is conserved.
 C Total momentum of the ball is conserved.
 D Total momentum of the system is conserved.

- 10 Two equal masses X and Y are moving towards each other on a frictionless air track as shown. The masses make an elastic collision. 9702/01/M/J/08

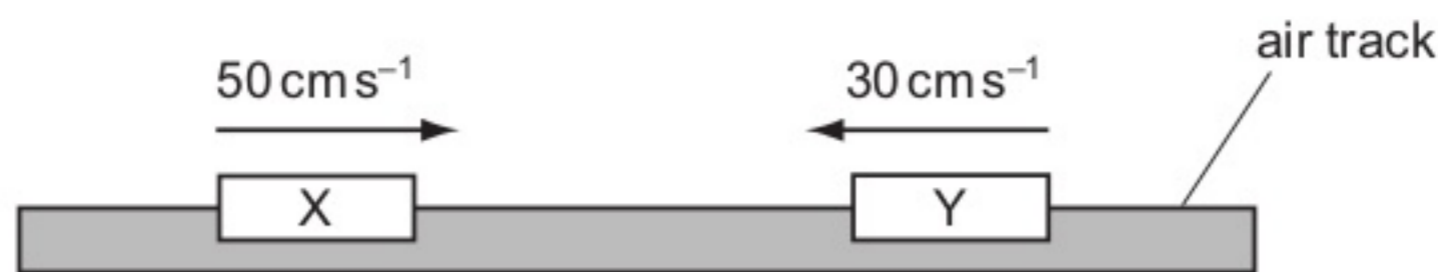

Which row gives possible velocities for the two masses after the collision?

	velocity of X	velocity of Y
A	zero	20 cm s ⁻¹ to the right
B	10 cm s ⁻¹ to the right	10 cm s ⁻¹ to the right
C	20 cm s ⁻¹ to the left	zero
D	30 cm s ⁻¹ to the left	50 cm s ⁻¹ to the right

- 11 A car of mass 750 kg has a horizontal driving force of 2.0 kN acting on it. It has a forward horizontal acceleration of 2.0 ms⁻². 9702/01/M/J/08

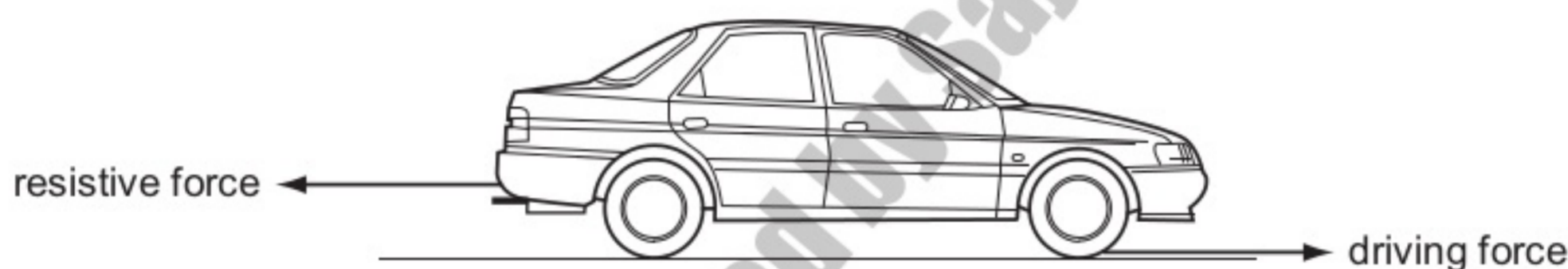

What is the resistive force acting horizontally?

- A** 0.5 kN **B** 1.5 kN **C** 2.0 kN **D** 3.5 kN

- 10 Two spheres approach each other along the same straight line. Their speeds are u_1 and u_2 before collision, and v_1 and v_2 after collision, in the directions shown below. 9702/01/O/N/08

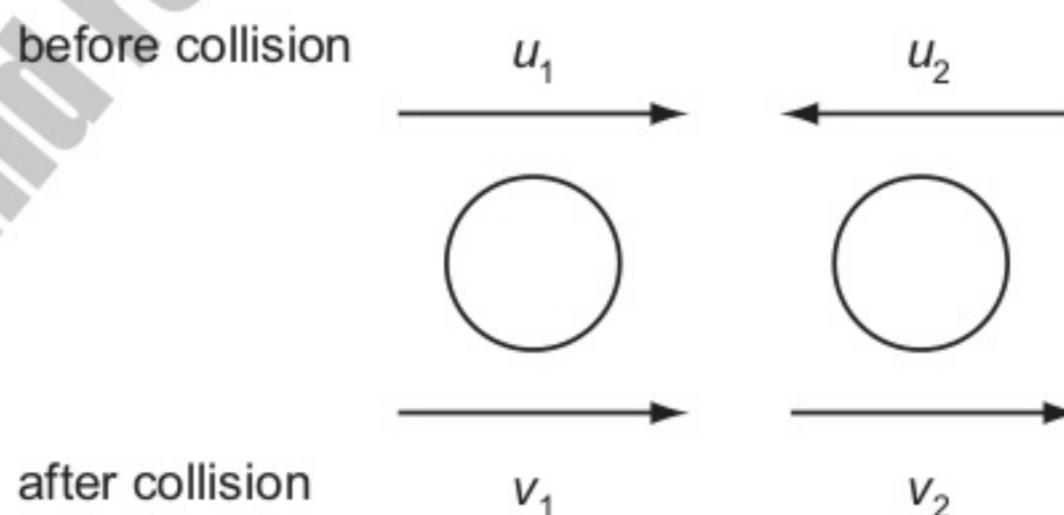

Which equation is correct if the collision is perfectly elastic?

- A** $u_1 - u_2 = v_2 + v_1$
B $u_1 - u_2 = v_2 - v_1$
C $u_1 + u_2 = v_2 + v_1$
D $u_1 + u_2 = v_2 - v_1$

- 9 A ball falls vertically and bounces on the ground.

9702/01/O/N/08

The following statements are about the forces acting while the ball is in contact with the ground.

Which statement is correct?

- A** The force that the ball exerts on the ground is always equal to the weight of the ball.
- B** The force that the ball exerts on the ground is always equal in magnitude and opposite in direction to the force the ground exerts on the ball.
- C** The force that the ball exerts on the ground is always less than the weight of the ball.
- D** The weight of the ball is always equal in magnitude and opposite in direction to the force that the ground exerts on the ball.
- 9 A tennis ball of mass 100 g is struck by a tennis racket. The velocity of the ball is changed as shown.

9702/01/M/J/09

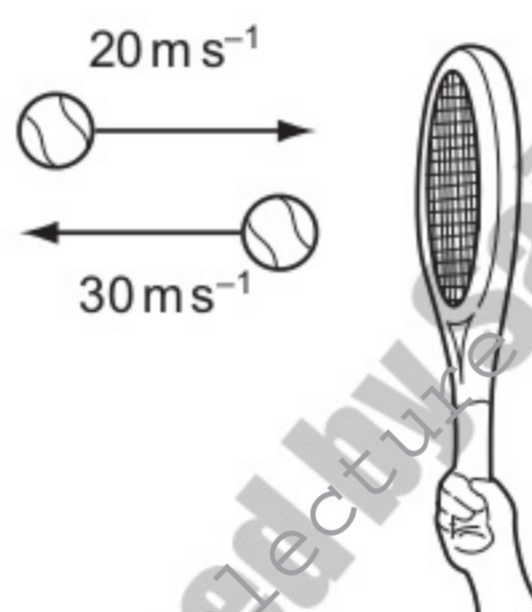

What is the magnitude of the change in momentum of the ball?

- A** 1 kg m s^{-1} **B** 5 kg m s^{-1} **C** 1000 kg m s^{-1} **D** 5000 kg m s^{-1}
- 10 A stationary body explodes into two components of masses m and $2m$.

9702/01/M/J/09

The components gain kinetic energies X and Y respectively.

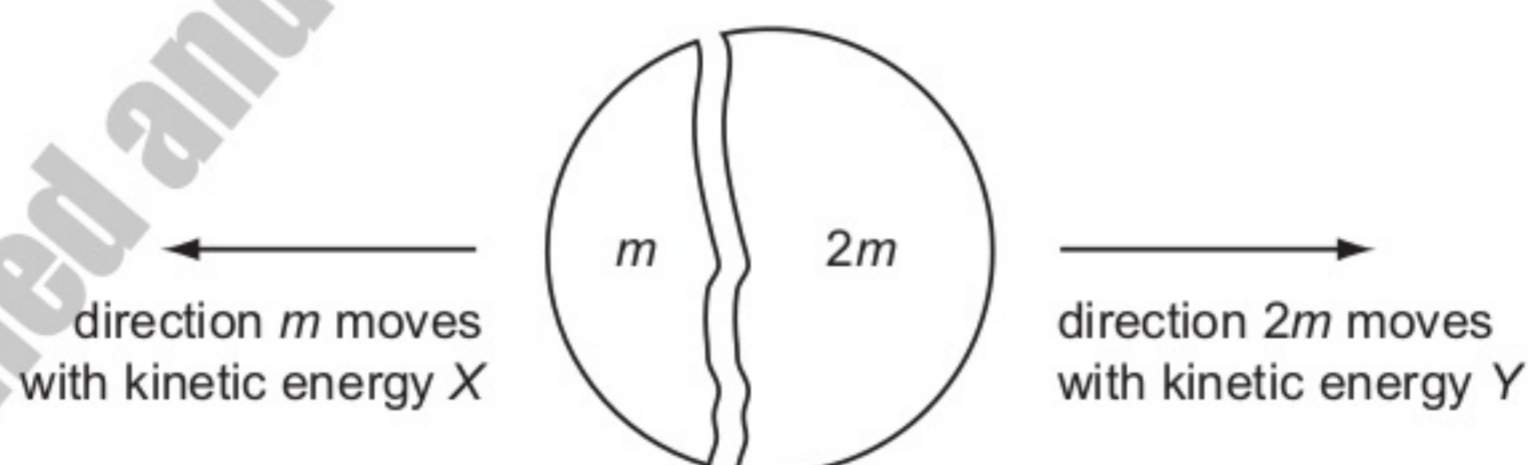

What is the value of the ratio $\frac{X}{Y}$?

- A** $\frac{1}{4}$ **B** $\frac{1}{2}$ **C** $\frac{2}{1}$ **D** $\frac{4}{1}$

- 8 The diagram shows two spherical masses approaching each other head-on at an equal speed u . One has mass $2m$ and the other has mass m . 9702/12/O/N/09



Which diagram, showing the situation after the collision, shows the result of an elastic collision?

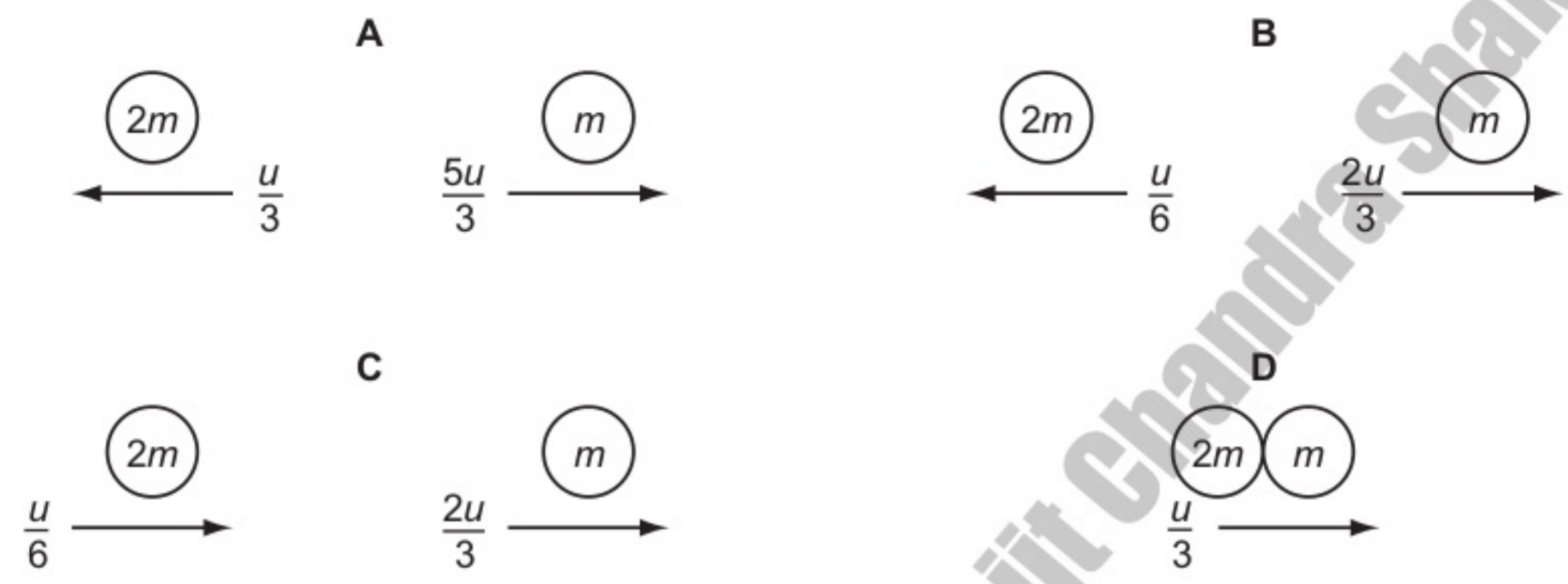

the spheres stick together

- 9 A supermarket trolley, total mass 30 kg, is moving at 3.0 ms^{-1} . A retarding force of 60 N is applied to the trolley for 0.50 s in the opposite direction to the trolley's initial velocity. 9702/12/O/N/09

What is the trolley's new velocity after the application of the force?

- A 1.0 ms^{-1} B 1.5 ms^{-1} C 2.0 ms^{-1} D 2.8 ms^{-1}

- 10 Two equal masses travel towards each other on a frictionless air track at speeds of 60 cm s^{-1} and 40 cm s^{-1} . They stick together on impact. 9702/11/M/J/10



What is the speed of the masses after impact?

- A 10 cm s^{-1} B 20 cm s^{-1} C 40 cm s^{-1} D 50 cm s^{-1}

- 11 A body, initially at rest, explodes into two masses M_1 and M_2 that move apart with speeds v_1 and v_2 respectively. 9702/11/O/N/10

What is the ratio $\frac{v_1}{v_2}$?

- A $\frac{M_1}{M_2}$ B $\frac{M_2}{M_1}$ C $\sqrt{\frac{M_1}{M_2}}$ D $\sqrt{\frac{M_2}{M_1}}$

12 The diagram shows two identical spheres X and Y.

9702/11/M/J/10

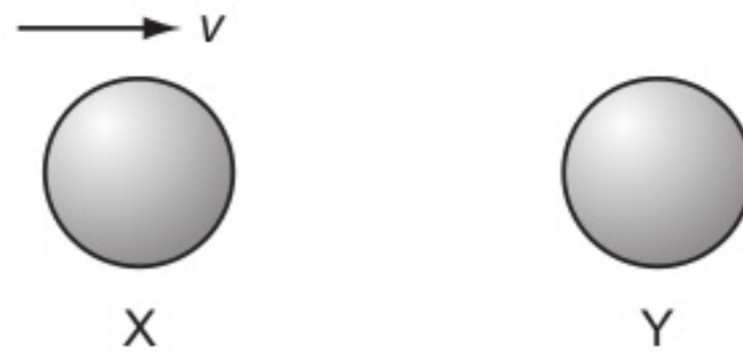

Initially, X moves with speed v directly towards Y. Y is stationary. The spheres collide elastically.

What happens?

	X	Y
A	moves with speed $\frac{1}{2}v$ to the right	moves with speed $\frac{1}{2}v$ to the right
B	moves with speed v to the left	remains stationary
C	moves with speed $\frac{1}{2}v$ to the left	moves with speed $\frac{1}{2}v$ to the right
D	stops	moves with speed v to the right

9 The diagram shows two identical spheres X and Y.

9702/13/M/J/10



Initially, X moves with speed v directly towards Y. Y is stationary. The spheres collide elastically.

What happens?

	X	Y
A	moves with speed $\frac{1}{2}v$ to the right	moves with speed $\frac{1}{2}v$ to the right
B	moves with speed v to the left	remains stationary
C	moves with speed $\frac{1}{2}v$ to the left	moves with speed $\frac{1}{2}v$ to the right
D	stops	moves with speed v to the right

10 Which defines the weight of a body?

9702/12/O/N/10

- A** the amount of matter in the body
- B** the force of gravity on the body
- C** the number of particles in the body
- D** the product of the body's volume and density

10 The diagram shows two identical spheres X and Y.

9702/12/M/J/10

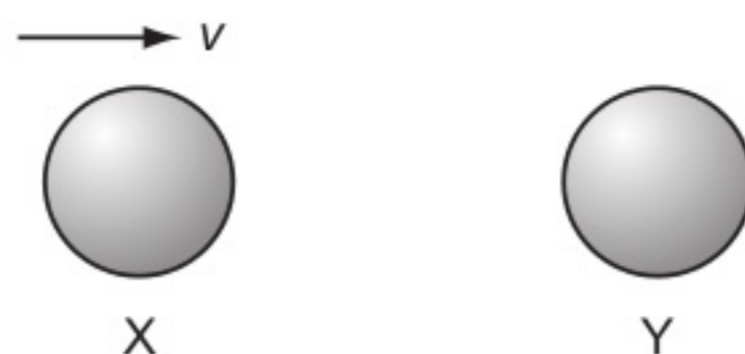

Initially, X moves with speed v directly towards Y. Y is stationary. The spheres collide elastically.

What happens?

	X	Y
A	moves with speed $\frac{1}{2}v$ to the right	moves with speed $\frac{1}{2}v$ to the right
B	moves with speed v to the left	remains stationary
C	moves with speed $\frac{1}{2}v$ to the left	moves with speed $\frac{1}{2}v$ to the right
D	stops	moves with speed v to the right

11 Two equal masses travel towards each other on a frictionless air track at speeds of 60 cm s^{-1} and 40 cm s^{-1} . They stick together on impact.

9702/12/M/J/10



What is the speed of the masses after impact?

- A** 10 cm s^{-1} **B** 20 cm s^{-1} **C** 40 cm s^{-1} **D** 50 cm s^{-1}

12 Two equal masses travel towards each other on a frictionless air track at speeds of 60 cm s^{-1} and 40 cm s^{-1} . They stick together on impact.

9702/13/M/J/10



What is the speed of the masses after impact?

- A** 10 cm s^{-1} **B** 20 cm s^{-1} **C** 40 cm s^{-1} **D** 50 cm s^{-1}

10 A molecule of mass m travelling horizontally with velocity u hits a vertical wall at right-angles to its velocity. It then rebounds horizontally with the same speed.

9702/11/M/J/11

What is its change in momentum?

- A** zero **B** mu **C** $-mu$ **D** $-2mu$

- 10** The gravitational field strength on the surface of planet P is one tenth of that on the surface of planet Q. 9702/11/O/N/10

On the surface of P, a body has a mass of 1.0 kg and a weight of 1.0 N.

What are the mass and weight of the same body on the surface of planet Q?

	mass on Q/kg	weight on Q/N
A	1.0	0.1
B	1.0	10
C	10	10
D	10	100

- 12** Two experiments are carried out using two trolleys of equal mass. All moving parts of the trolleys are frictionless, as is the surface that the trolleys move over. In both experiments, trolley X moves towards trolley Y, which is initially stationary. 9702/11/O/N/10



After the collision in experiment 1, X is stationary and Y moves off to the right.

After the collision in experiment 2, the trolleys join and move off together.

What types of collision occur in these experiments?

	experiment 1	experiment 2
A	elastic	elastic
B	elastic	inelastic
C	inelastic	elastic
D	inelastic	inelastic

- 9** A body, initially at rest, explodes into two masses M_1 and M_2 that move apart with speeds v_1 and v_2 respectively. 9702/13/O/N/10

What is the ratio $\frac{v_1}{v_2}$?

- A** $\frac{M_1}{M_2}$ **B** $\frac{M_2}{M_1}$ **C** $\sqrt{\frac{M_1}{M_2}}$ **D** $\sqrt{\frac{M_2}{M_1}}$

- 11** The momentum of an object changes from 160 kg m s^{-1} to 240 kg m s^{-1} in 2s. 9702/12/M/J/11

What is the mean resultant force on the object during the change?

- A** 40N **B** 80N **C** 200N **D** 400N

9 A particle of mass $2m$ and velocity v strikes a wall.

9702/12/O/N/10

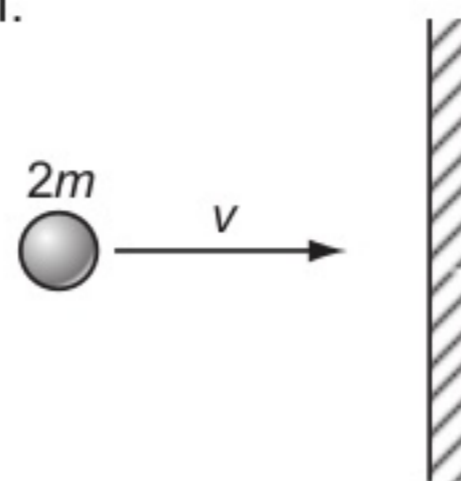

The particle rebounds along the same path after colliding with the wall. The collision is inelastic.

What is a possible change in the momentum of the ball during the collision?

- A** mv **B** $2mv$ **C** $3mv$ **D** $4mv$

8 The gravitational field strength on the surface of planet P is one tenth of that on the surface of planet Q.

9702/13/O/N/10

On the surface of P, a body has a mass of 1.0 kg and a weight of 1.0 N .

What are the mass and weight of the same body on the surface of planet Q?

	mass on Q/kg	weight on Q/N
A	1.0	0.1
B	1.0	10
C	10	10
D	10	100

10 Two experiments are carried out using two trolleys of equal mass. All moving parts of the trolleys are frictionless, as is the surface that the trolleys move over. In both experiments, trolley X moves towards trolley Y, which is initially stationary.

9702/13/O/N/10



After the collision in experiment 1, X is stationary and Y moves off to the right.

After the collision in experiment 2, the trolleys join and move off together.

What types of collision occur in these experiments?

	experiment 1	experiment 2
A	elastic	elastic
B	elastic	inelastic
C	inelastic	elastic
D	inelastic	inelastic

- 8 A body has a weight of 58.9 N when on the Earth. On the Moon, the acceleration of free fall is 1.64 m s^{-2} . 9702/11/M/J/11

What are the weight and the mass of the body when it is on the Moon?

	weight/N	mass/kg
A	9.85	1.00
B	9.85	6.00
C	58.9	1.00
D	58.9	6.00

- 9 A body of mass m , moving at velocity v , collides with a stationary body of the same mass and sticks to it. 9702/11/M/J/11

Which row describes the momentum and kinetic energy of the two bodies after the collision?

	momentum	kinetic energy
A	mv	$\frac{1}{4}mv^2$
B	mv	$\frac{1}{8}mv^2$
C	$2mv$	$\frac{1}{2}mv^2$
D	$2mv$	mv^2

- 10 A force F is applied to a freely moving object. At one instant of time, the object has velocity v and acceleration a . 9702/12/M/J/11

Which quantities **must** be in the same direction?

- A** a and v only
- B** a and F only
- C** v and F only
- D** v , F and a

- 12 A car accelerates in a straight line. 9702/12/M/J/11

A graph of the momentum of the car is plotted against time.

What is evaluated by finding the gradient of the graph at a particular time?

- A** the acceleration of the car
- B** the resultant force on the car
- C** the kinetic energy of the car
- D** the power supplied to the car

- 13 The diagram shows a particle P, travelling at speed v , about to collide with a stationary particle Q of the same mass. The collision is perfectly elastic. 9702/12/M/J/11

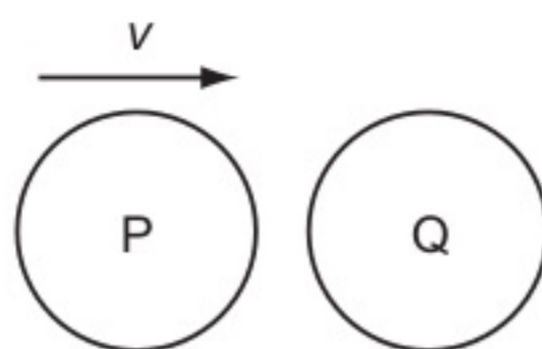

Which statement describes the motion of P and of Q immediately after the collision?

- A P rebounds with speed $\frac{1}{2}v$ and Q acquires speed $\frac{1}{2}v$.
 B P rebounds with speed v and Q remains stationary.
 C P and Q both travel in the same direction with speed $\frac{1}{2}v$.
 D P comes to a standstill and Q acquires speed v .
- 9 A molecule of mass m travelling horizontally with velocity u hits a vertical wall at right-angles to its velocity. It then rebounds horizontally with the same speed. 9702/13/M/J/11

What is its change in momentum?

- A zero B mu C $-mu$ D $-2mu$
- 10 A body of mass m , moving at velocity v , collides with a stationary body of the same mass and sticks to it.

Which row describes the momentum and kinetic energy of the two bodies after the collision? 9702/13/M/J/11

	momentum	kinetic energy
A	mv	$\frac{1}{4}mv^2$
B	mv	$\frac{1}{8}mv^2$
C	$2mv$	$\frac{1}{2}mv^2$
D	$2mv$	mv^2

- 6 A body has a weight of 58.9 N when on the Earth. On the Moon, the acceleration of free fall is 1.64 m s^{-2} . 9702/13/M/J/11

What are the weight and the mass of the body when it is on the Moon?

	weight/N	mass/kg
A	9.85	1.00
B	9.85	6.00
C	58.9	1.00
D	58.9	6.00

10 What is the **definition** of the force on a body?

9702/11/O/N/11

- A the mass of the body multiplied by its acceleration
- B the power input to the body divided by its velocity
- C the rate of change of momentum of the body
- D the work done on the body divided by its displacement

11 A car accelerates from rest. The graph shows the momentum of the car plotted against time.

9702/11/O/N/11

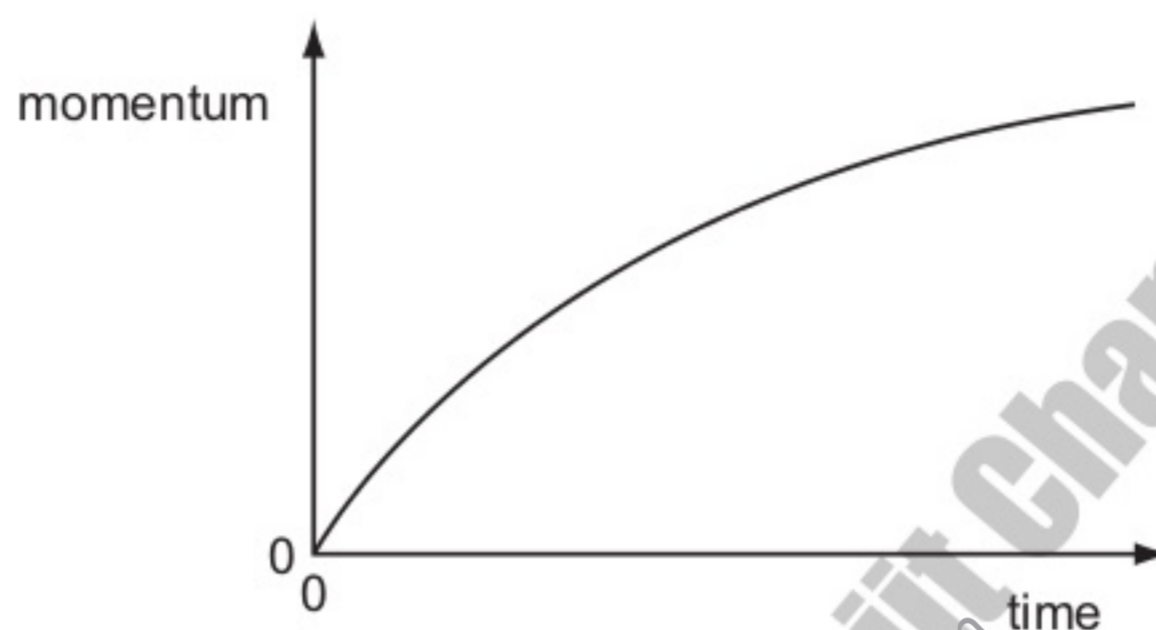

What is the meaning of the gradient of the graph at a particular time?

- A the resultant force on the car
- B the velocity of the car
- C the kinetic energy of the car
- D the rate of change of kinetic energy of the car

12 An ice-hockey puck slides along a horizontal, frictionless ice-rink surface. It collides inelastically with a wall at right angles to its path, and then rebounds along its original path.

9702/11/O/N/11

Which graph shows the variation with time t of the momentum p of the puck?

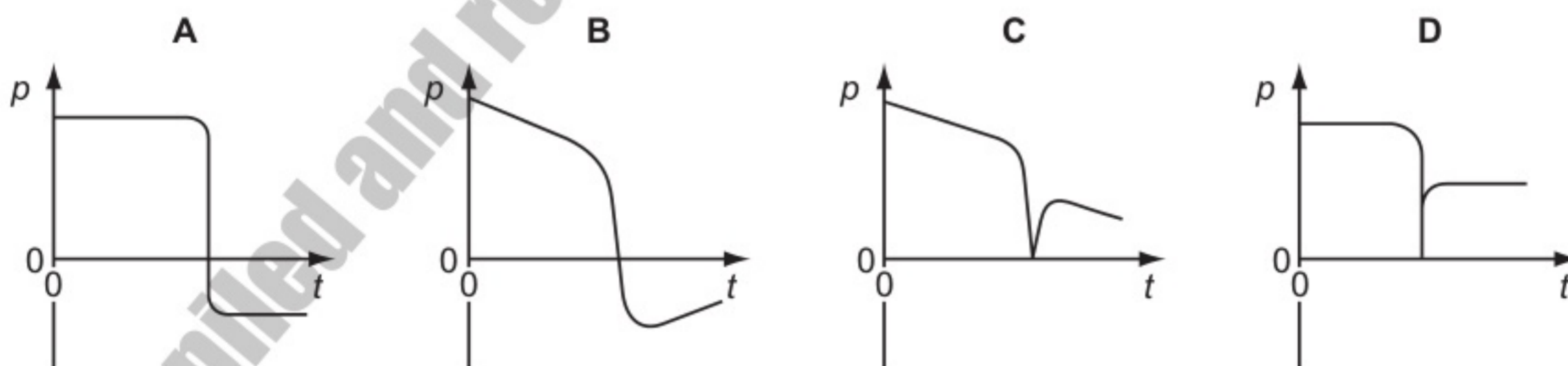

11 An object of mass 20 kg is travelling at a constant speed of 6.0 ms^{-1} .

9702/12/O/N/11

It collides with an object of mass 12 kg travelling at a constant speed of 15 m s^{-1} in the opposite direction. The objects stick together.

What is the speed of the objects immediately after the collision?

- A 1.9 ms^{-1}
- B 9.0 ms^{-1}
- C 9.4 ms^{-1}
- D 21 ms^{-1}

- 9 A golf ball is hit by a club. The graph shows the variation with time of the force exerted on the ball by the club.

9702/12/O/N/11



Which quantity, for the time of contact, **cannot** be found from the graph?

- A** the average force on the ball
B the change in momentum of the ball
C the contact time between the ball and the club
D the maximum acceleration of the ball
- 10 A group of students investigating the principle of conservation of momentum use a small truck travelling over a frictionless surface.

9702/12/O/N/11

Sand is dropped into the truck as it passes X. At Y, a trapdoor in the bottom of the truck opens and the sand falls out.



How does the velocity of the truck change when the sand is added to the truck at X and then leaves the truck at Y?

	at X	at Y
A	decreases	increases
B	decreases	stays the same
C	stays the same	increases
D	stays the same	stays the same

- 11 What is the **definition** of the force on a body?
- A** the mass of the body multiplied by its acceleration
B the power input to the body divided by its velocity
C the rate of change of momentum of the body
D the work done on the body divided by its displacement

- 10** An ice-hockey puck slides along a horizontal, frictionless ice-rink surface. It collides inelastically with a wall at right angles to its path, and then rebounds along its original path. 9702/13/O/N/11

Which graph shows the variation with time t of the momentum p of the puck?

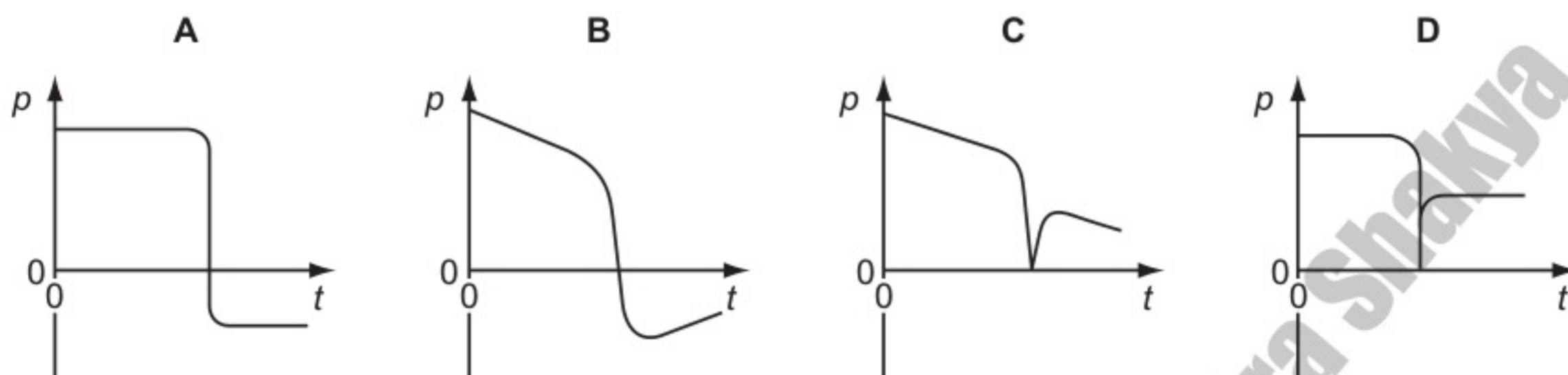

- 12** A car accelerates from rest. The graph shows the momentum of the car plotted against time. 9702/13/O/N/11

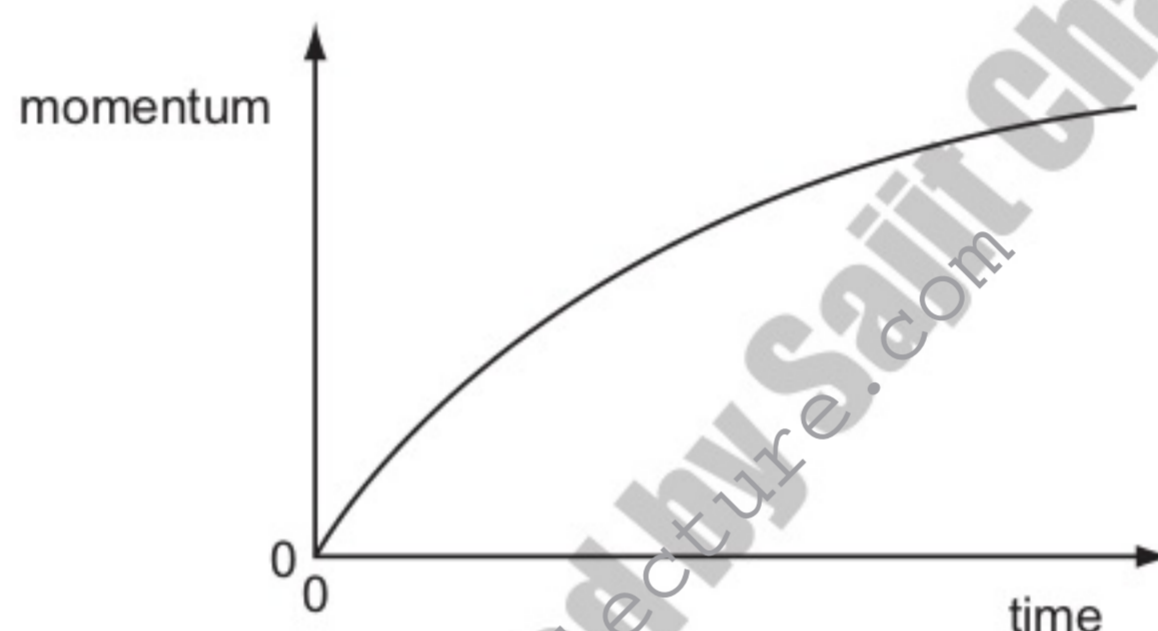

What is the meaning of the gradient of the graph at a particular time?

- A** the resultant force on the car
 - B** the velocity of the car
 - C** the kinetic energy of the car
 - D** the rate of change of kinetic energy of the car
- 11** Which row correctly states whether momentum and kinetic energy are conserved in an inelastic collision in which there are no external forces? 9702/12/M/J/12

	momentum	kinetic energy
A	conserved	conserved
B	conserved	not conserved
C	not conserved	conserved
D	not conserved	not conserved

- 12 Two spheres approach each other along the same straight line. Their speeds are u_1 and u_2 before collision. After the collision, the spheres separate with speeds v_1 and v_2 in the directions shown below.

9702/12/M/J/12



Which equation must be correct if the collision is perfectly elastic?

- A $u_1 - u_2 = v_2 + v_1$
 B $u_1 - u_2 = v_2 - v_1$
 C $u_1 + u_2 = v_2 + v_1$
 D $u_1 + u_2 = v_2 - v_1$

- 10 Each option gives a correct word equation involving force.

9702/12/M/J/12

Which option gives the definition of force?

- A force = energy divided by displacement
 B force = mass \times acceleration
 C force = pressure \times area
 D force = rate of change of momentum

- 11 Two similar spheres, each of mass m and travelling with speed v , are moving towards each other.

9702/12/M/J/12

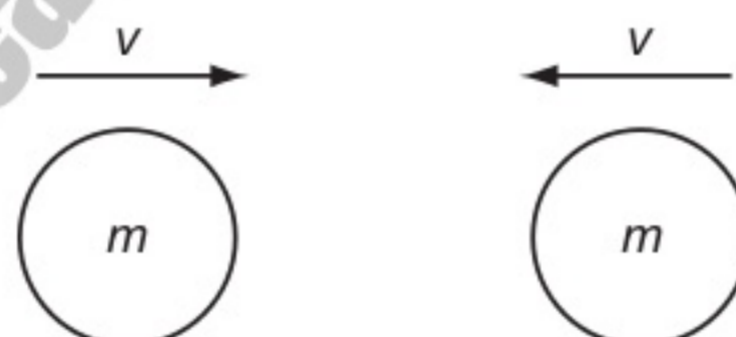

The spheres have a head-on elastic collision.

Which statement is correct?

- A The spheres stick together on impact.
 B The total kinetic energy after impact is mv^2 .
 C The total kinetic energy before impact is zero.
 D The total momentum before impact is $2mv$.

- 11 Each option gives a correct word equation involving force.

9702/13/M/J/12

Which option gives the definition of force?

- A force = energy divided by displacement
- B force = mass \times acceleration
- C force = pressure \times area
- D force = rate of change of momentum

- 12 Two similar spheres, each of mass m and travelling with speed v , are moving towards each other.

9702/13/M/J/12

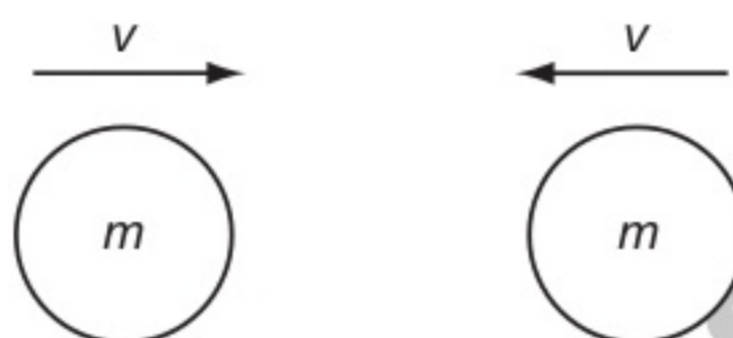

The spheres have a head-on elastic collision.

Which statement is correct?

- A The spheres stick together on impact.
- B The total kinetic energy after impact is mv^2 .
- C The total kinetic energy before impact is zero.
- D The total momentum before impact is $2mv$.

- 11 The velocity of a car changes as shown.

9702/12/O/N/12

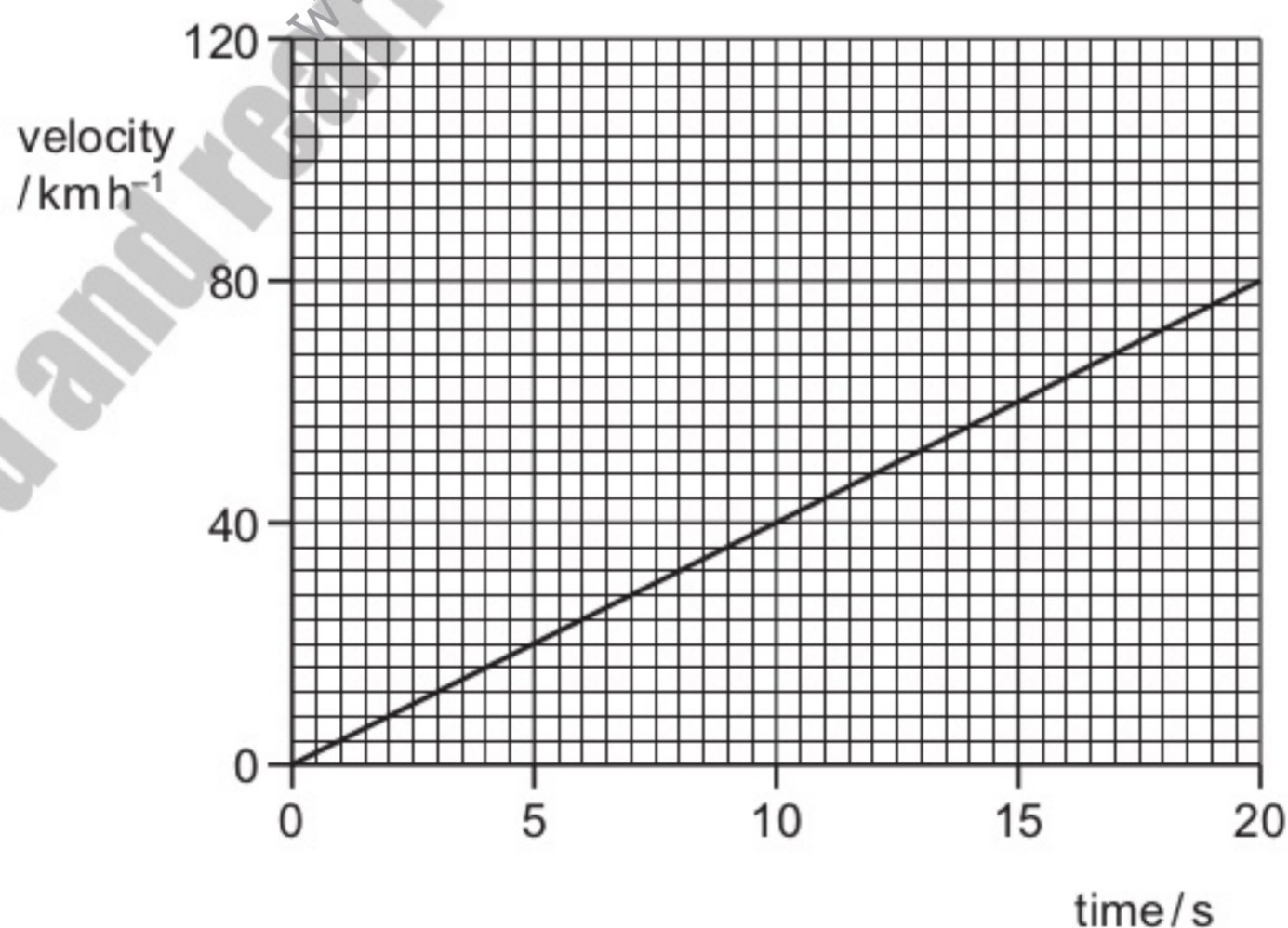

What is the acceleration of the car?

- A 1.1 ms^{-2}
- B 4.0 ms^{-2}
- C 224 ms^{-2}
- D 800 ms^{-2}

- 13** Two identical, perfectly elastic spheres have the same mass m . They travel towards each other with the same speed v along a horizontal frictionless surface. 9702/12/O/N/12

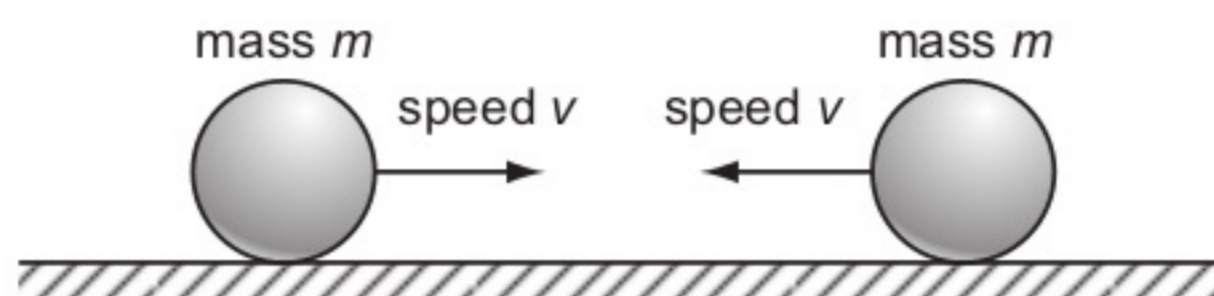

Which statement about the sum of the kinetic energies of the spheres is correct?

- A** The sum of their kinetic energies before impact is zero.
 - B** The sum of their kinetic energies before impact is $\frac{1}{2}mv^2$.
 - C** The sum of their kinetic energies after impact is zero.
 - D** The sum of their kinetic energies after impact is mv^2 .
- 14** A 1.2 kg mass is supported by a person's hand and two newton-meters as shown. 9702/12/O/N/12

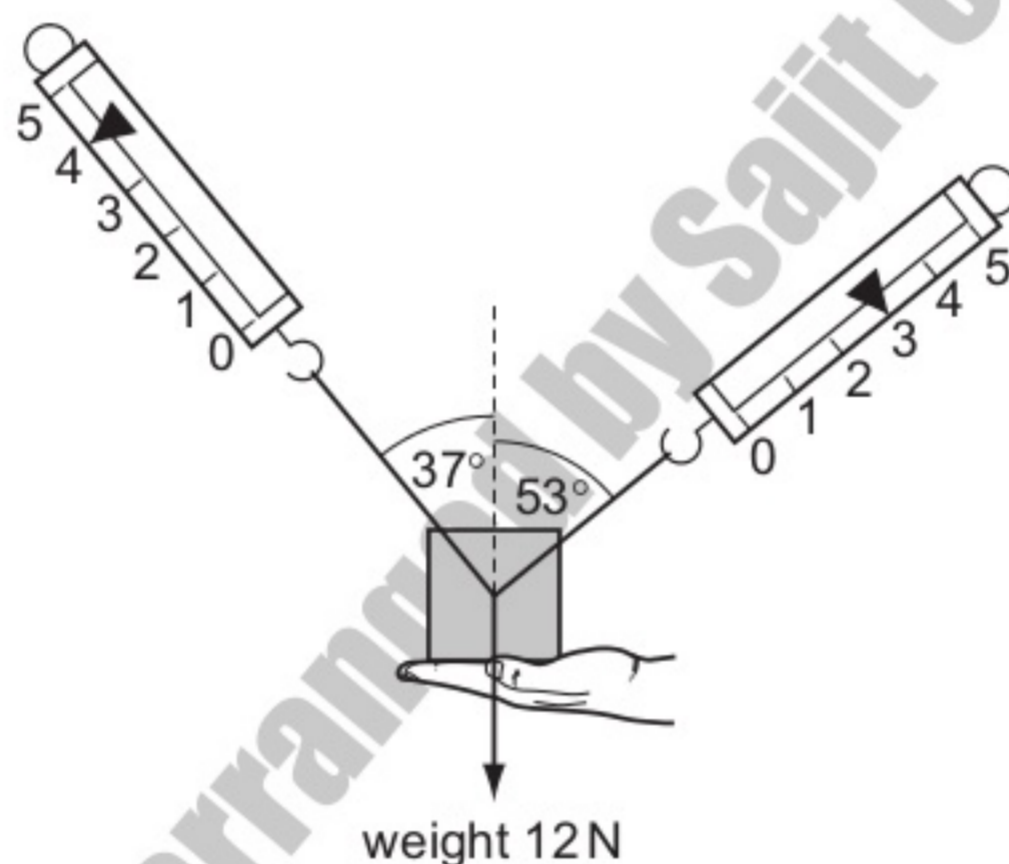

When the person's hand is removed, what is the initial vertical acceleration of the mass?

- A** 0.6 ms^{-2}
 - B** 2 ms^{-2}
 - C** 4 ms^{-2}
 - D** 6 ms^{-2}
- 12** A ball of mass 0.5 kg is thrown against a wall at a speed of 12 m s^{-1} . It bounces back with a speed of 8 m s^{-1} . The collision lasts for 0.10 s. 9702/12/O/N/12

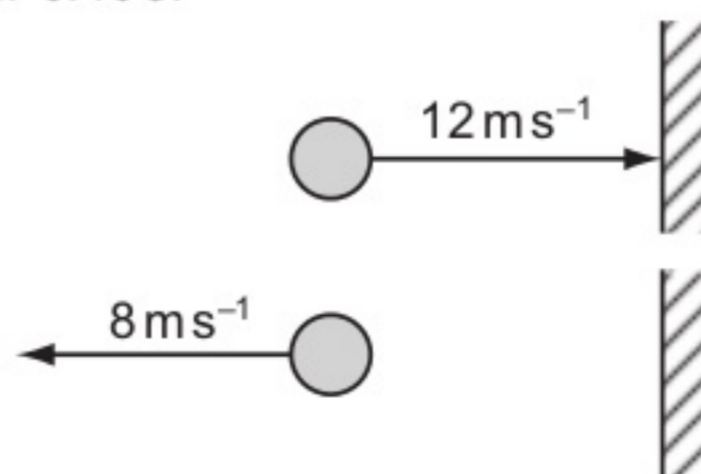

What is the average force on the ball due to the collision?

- A** 0.2 N
- B** 1 N
- C** 20 N
- D** 100 N

15 A lorry of mass 20 000 kg has a constant resultant force F acting on it.

9702/12/O/N/12

It accelerates from 6.0 ms^{-1} to 30.0 ms^{-1} in a time of 300 s.

What is the change in momentum of the lorry and the value of F ?

	change in momentum/Ns	force F /N
A	48 000	160
B	480 000	1600
C	600 000	2000
D	600 000	20 000

16 A stationary body floats in water.

9702/12/O/N/12

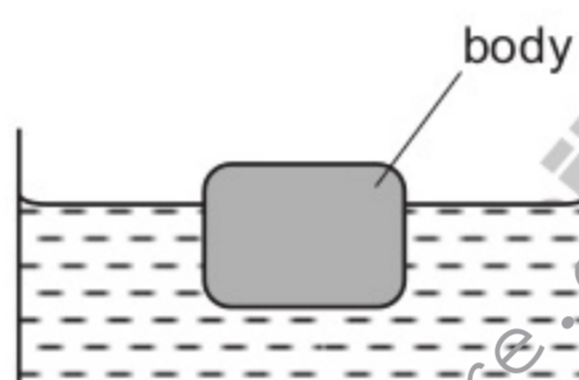

Which statement about the forces acting on the body is correct?

- A** The gravitational force is equal to the viscous force.
- B** The gravitational force is greater than the upthrust.
- C** The upthrust is zero.
- D** The viscous force is zero.

11 An object travelling with velocity v strikes a wall and rebounds as shown.

9702/11/O/N/12

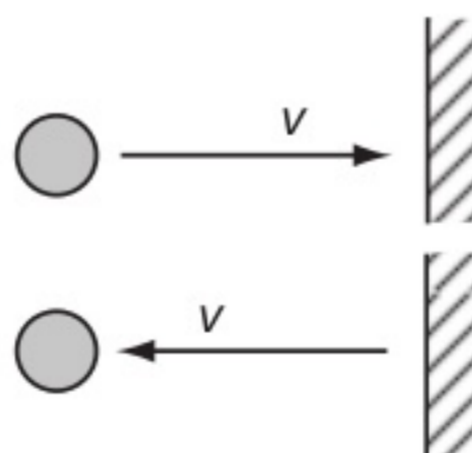

Which property of the object is **not** conserved?

- A** kinetic energy
- B** mass
- C** momentum
- D** speed

- 12 A particle X has speed v and collides with a stationary identical particle Y. The collision is perfectly elastic.

9702/11/O/N/12

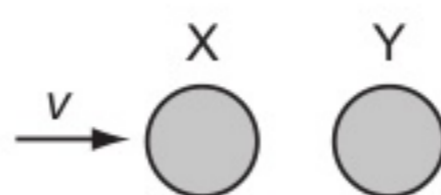

What are the speed and direction of motion of each of the two particles after the collision?

	X	Y
A	stationary	v to the right
B	$\frac{v}{2}$ to the right	$\frac{v}{2}$ to the right
C	$\frac{v}{2}$ to the left	$\frac{v}{2}$ to the right
D	v to the left	stationary

- 13 A mass of 2.0 kg rests on a frictionless surface. It is attached to a 1.0 kg mass by a light, thin string which passes over a frictionless pulley. The 1.0 kg mass is released and it accelerates downwards.

9702/11/O/N/12

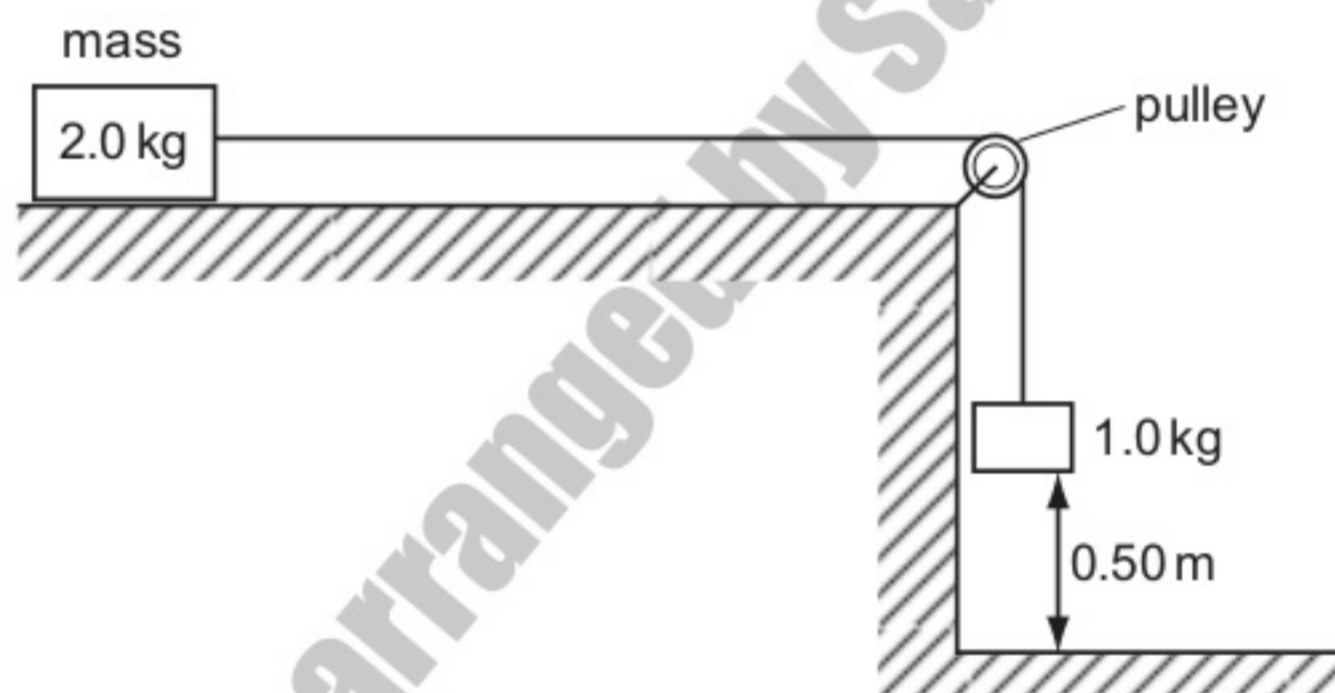

What is the speed of the 2.0 kg mass as the 1.0 kg mass hits the floor, having fallen a distance of 0.50 m?

- A** 1.8 ms^{-1} **B** 2.2 ms^{-1} **C** 3.1 ms^{-1} **D** 9.8 ms^{-1}

- 14 A lead pellet is shot vertically upwards into a clay block that is stationary at the moment of impact but is able to rise freely after impact.

9702/11/O/N/12

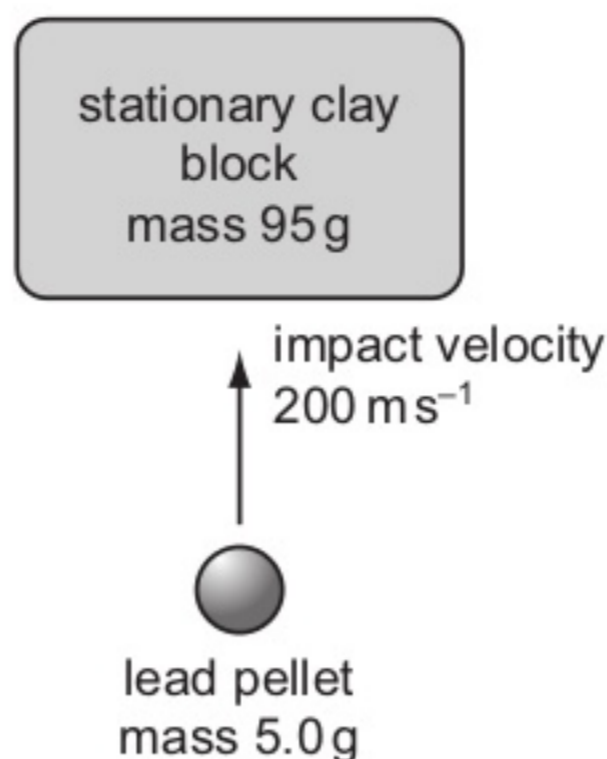

The pellet hits the block with an initial velocity of 200 m s^{-1} . It embeds itself in the block and does not emerge.

How high above its initial position will the block rise?
(Mass of pellet = 5.0 g; mass of clay block = 95 g.)

- A** 5.1 m **B** 5.6 m **C** 10 m **D** 2000 m

- 11 The diagram shows two spherical masses approaching each other head-on at an equal speed u . One is of mass m and the other of mass $2m$.

9702/13/O/N/12



Which diagram, showing the situation after the collision, is **not** consistent with the principle of conservation of momentum?

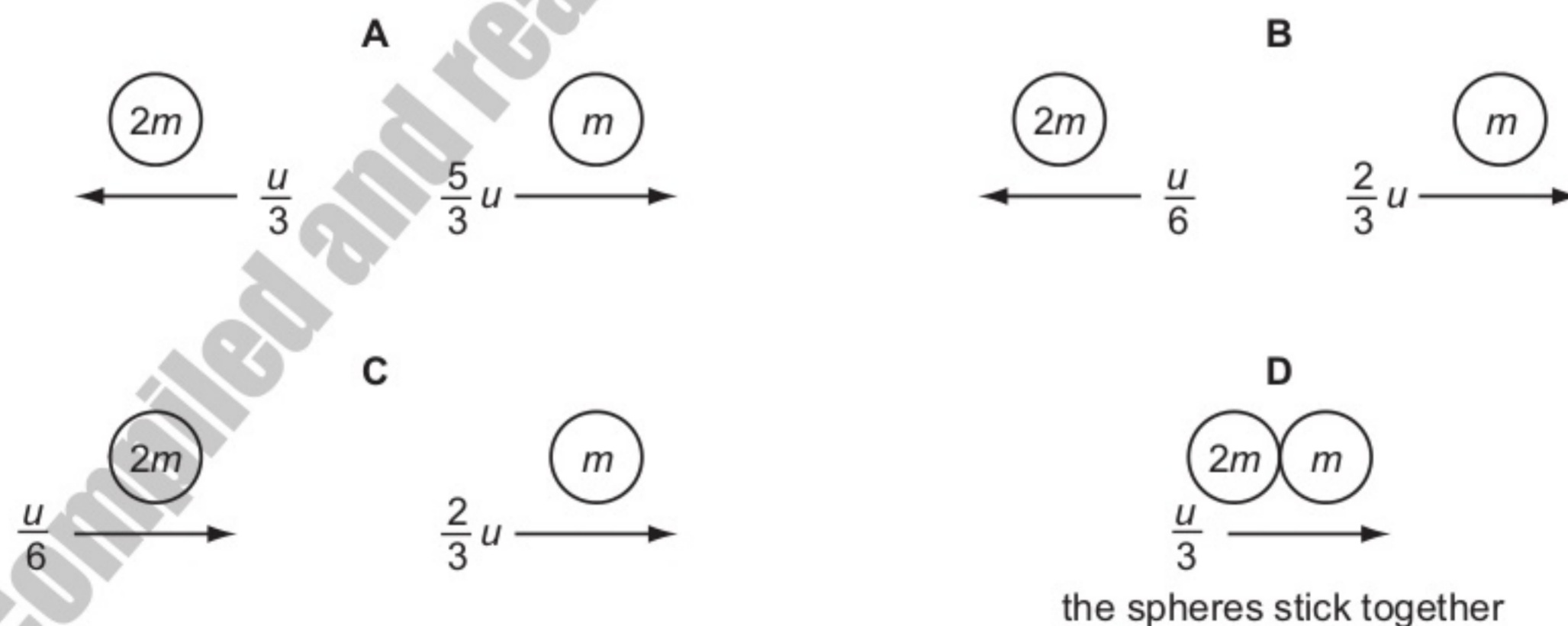

- 12** A molecule of mass m travelling at speed v hits a wall in a direction perpendicular to the wall. The collision is elastic. 9702/13/O/N/12

What are the changes in the kinetic energy and in the momentum of the molecule caused by the collision?

	change in momentum	change in kinetic energy
A	0	0
B	0	mv^2
C	$2mv$	0
D	mv^2	0

- 13** The IKAROS satellite has mass 320 kg and moves through space using a solar sail of area 20 m^2 . The average solar wind pressure is $1.0 \times 10^{-5} \text{ N m}^{-2}$. 9702/13/O/N/12

What is the acceleration of the satellite caused by the solar wind?

- A** $3.1 \times 10^{-8} \text{ ms}^{-2}$
B $6.3 \times 10^{-7} \text{ ms}^{-2}$
C $3.2 \times 10^{-3} \text{ ms}^{-2}$
D $6.4 \times 10^{-2} \text{ ms}^{-2}$
- 14** The graph shows the momentum of a cyclist over a period of 8.0 s. 9702/13/O/N/12

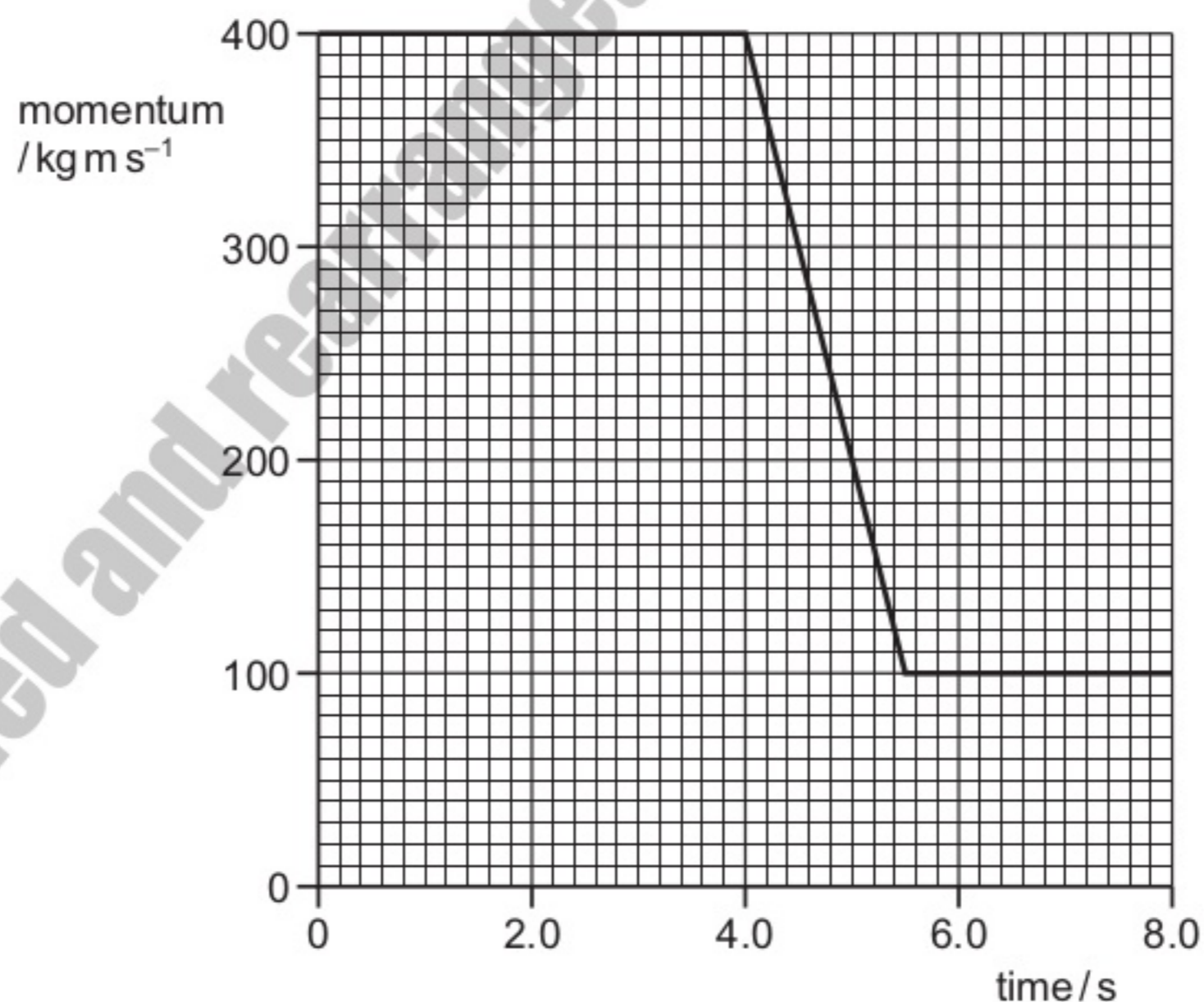

At time 4.0 s, she applies the brakes.

What is the resultant force on the cyclist during the period when the brakes are applied?

- A** 55 N **B** 200 N **C** 270 N **D** 450 N