

Forces - 2018

1. 9702/11/M/J/18/No.10

A horizontal metal bar PQ of length 50.0 cm is hinged at end P. The diagram shows the metal bar viewed from above.

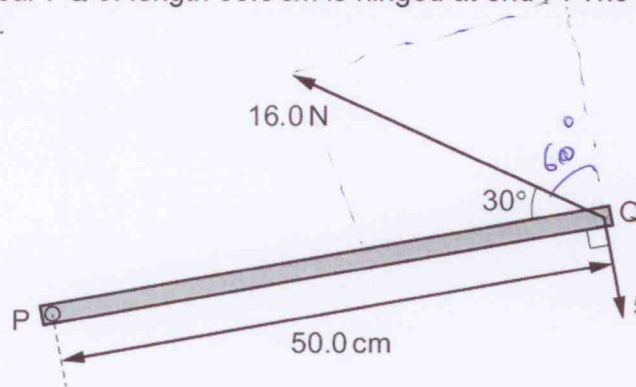

$C \cdot w \cdot m = 5.0 \text{ N} \times 0.5 \text{ m} = 2.5 \text{ Nm}$

$a \cdot c \cdot w \cdot m = 16 \sin 30^\circ \times 0.5 = 4 \text{ Nm}$

Moments opposite to each other

Sum = $4 + -2.5 = 1.5 \text{ Nm}$

Two forces of 16.0 N and 5.0 N are in the horizontal plane and act on end Q as shown in the diagram.

What is the total moment about P due to the two forces?

- A 1.5 Nm B 4.4 Nm C 6.5 Nm D 9.4 Nm

2. 9702/11/M/J/18/No.12

Two parallel forces, each of magnitude F , act on a rod of length $5d$.

Which diagram shows the positions of the two forces that will produce the largest torque on the rod?

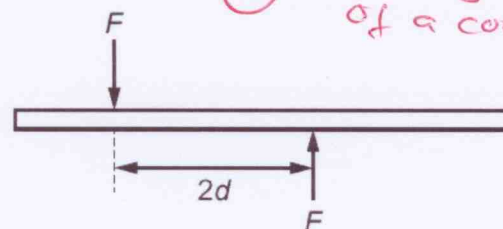
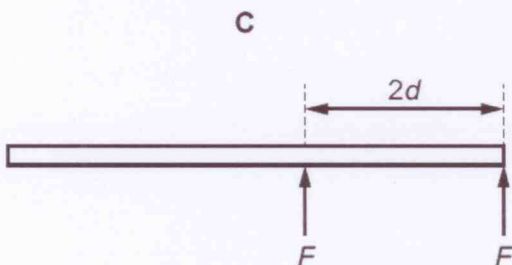
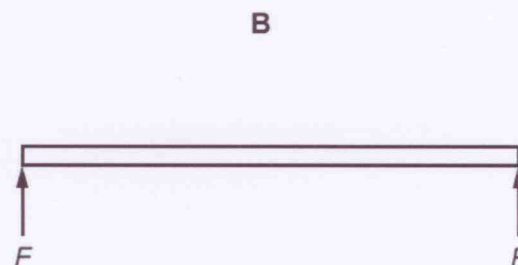
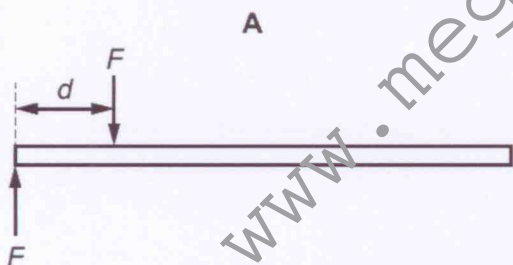

D - Torque is the turning effect of a couple.

3. 9702/12/M/J/18/No.11

An astronaut throws a stone horizontally near to the surface of the Moon, where there is no atmosphere.

Which row describes the horizontal and vertical forces acting on the stone after release?

	horizontal force	vertical force
A	non-zero and constant	constant
B	non-zero and constant	decreasing
C	zero	constant
D	zero	decreasing

- horizontal speed is constant
 - so horizontal force is zero
 - vertical force is due to gravity of the moon which is constant

4. 9702/12/M/J/18/No.13

A uniform diving-board is held by two fixed rods at points P and Q. A person stands at end R of the diving-board, as shown.

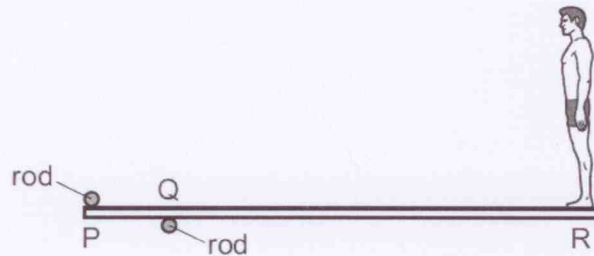

The forces exerted by the rods on the board are vertical. The board remains in equilibrium as the person slowly moves towards point Q from end R.

Which row describes the changes to the forces exerted by the rods on the board?

	force at P	force at Q
A	decreases	decreases
B	decreases	increases
C	increases	decreases
D	increases	increases

5. 9702/12/M/J/18/No.14

Two forces, each of magnitude F , act in opposite directions on a rod.

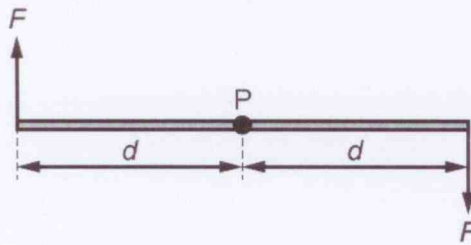

$\text{torque} = F \times d$
 $d = 2d$
 $= F \times 2d$
 $= \underline{\underline{2F \times d}}$

Each force acts on the rod at a distance d from the pivot P.

What is the torque of this couple about P?

- A 0 B $F \times d$ C $2F \times d$ D $2F \times 2d$

6. 9702/12/M/J/18/No.15

The vector diagram shows three coplanar forces acting on an object at P.

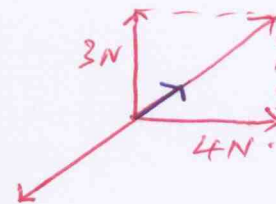
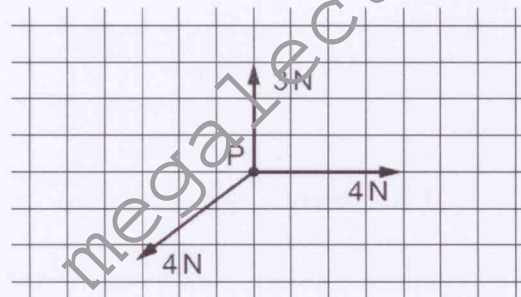

The magnitude of the resultant of these three forces is 1 N.

What is the direction of this resultant force?

- A B C D

7. 9702/12/M/J/18/No.17

The diagram shows a ball of weight W hanging in equilibrium from a string.

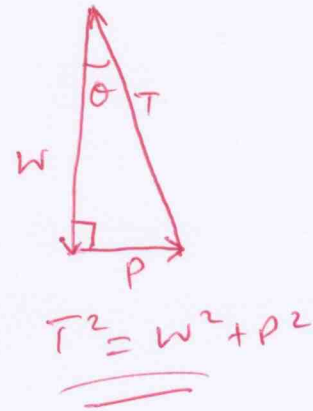
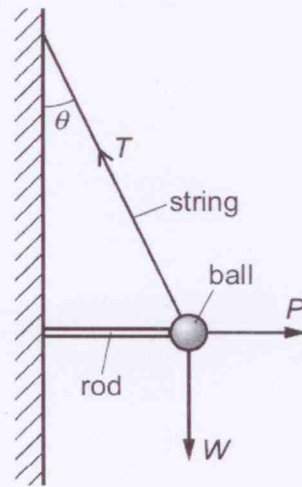

The string is at an angle θ to the vertical. The tension in the string is T . The ball is held away from the wall by a horizontal force P from a metal rod.

What is the relationship between the magnitudes of T , P and W ?

- A $P = T \cos \theta$ and $W = T \sin \theta$
- B $T = P + W$
- C $T^2 = P^2 + W^2$
- D $W = P \tan \theta$ and $W = T \cos \theta$

8. 9702/13/M/J/18/No.12

Which diagram shows a couple formed by two forces, each of magnitude F , acting on a rod?

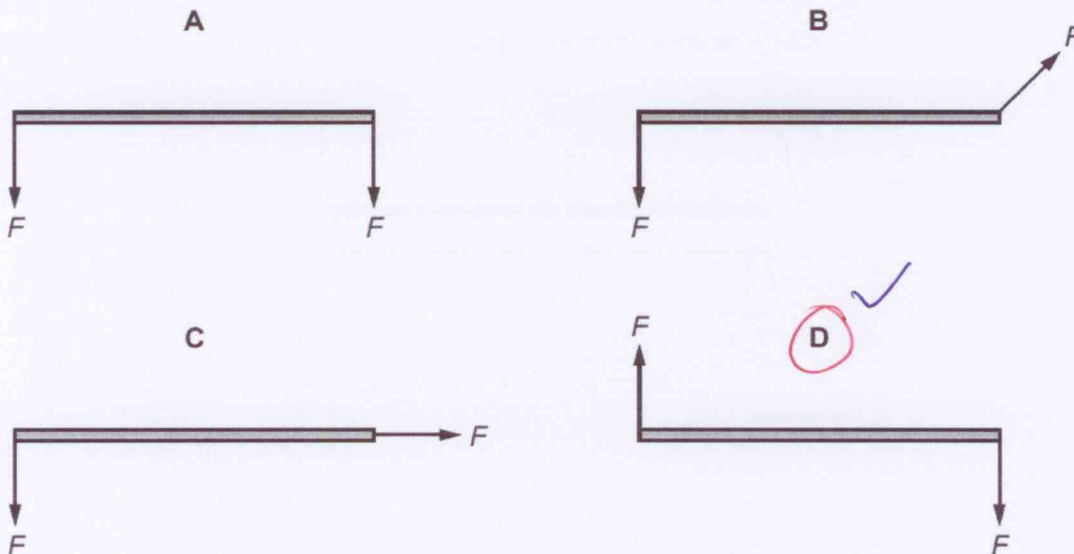

9. 9702/12/F/M/18/No.11

The diagram shows four forces applied to a circular object.

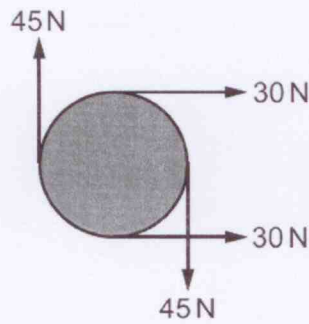

- Forces 45N creates a torque
 - Forces 30N has a resultant force.

Which row describes the resultant force and resultant torque on the object?

	resultant force	resultant torque
<input checked="" type="radio"/> A	non-zero	non-zero
<input type="radio"/> B	non-zero	zero
<input type="radio"/> C	zero	non-zero
<input type="radio"/> D	zero	zero

10. 9702/12/F/M/18/No.13

In which example is it **not** possible for the underlined body to be in equilibrium?

- A An aeroplane climbs at a steady rate.
- B An aeroplane tows a glider at a constant altitude.
- C A speedboat changes direction at a constant speed.
- D Two boats tow a ship into harbour.

www.megalecture.com